

MODEL	CAPACITY	CAPACITY	CAPACITY	CAPACITY	"A" TOTAL UNIT WIDTH	"B" RAMP WIDTH
HED-66	<input type="checkbox"/> 20,000LBS	<input type="checkbox"/> 25,000LBS	<input type="checkbox"/> 30,000LBS	<input type="checkbox"/> 35,000LBS	104'	66'
HED-72	<input type="checkbox"/> 20,000LBS	<input type="checkbox"/> 25,000LBS	<input type="checkbox"/> 30,000LBS	<input type="checkbox"/> 35,000LBS	110'	72'
HED-78	<input type="checkbox"/> 20,000LBS	<input type="checkbox"/> 25,000LBS	<input type="checkbox"/> 30,000LBS	<input type="checkbox"/> 35,000LBS	116'	78'
HED-84	<input type="checkbox"/> 20,000LBS	<input type="checkbox"/> 25,000LBS	<input type="checkbox"/> 30,000LBS	<input type="checkbox"/> 35,000LBS	122'	84'

ALL DIMENSIONS IN INCHES

EACH HYDRAULIC EDD CONSISTS OF:  
 1 HEDD, WIDTH, CAPACITY, AND VOLTAGE AS SELECTED  
 2 STEEL BUMPER BLOCKOUTS WITH MOLDED BUMPERS  
 1 CONTROL PANEL OF SPECIFIED VOLTAGE

OPERATION:

SINGLE PUSHBUTTON CONTROL STATION TO HYDRAULICALLY RAISE MAIN RAMP AND EXTEND LIP. LIP REMAINS EXTENDED WHILE RAMP FLOATS DOWN TO TRUCK BED. LIP AUTOMATICALLY RETURNS TO PENDENT POSITION WHEN TRUCK DEPARTS.

AVAILABLE VOLTAGES (SELECT ONE)

- 110/1/60
- 220/1/60
- 220/3/60
- 440/3/60

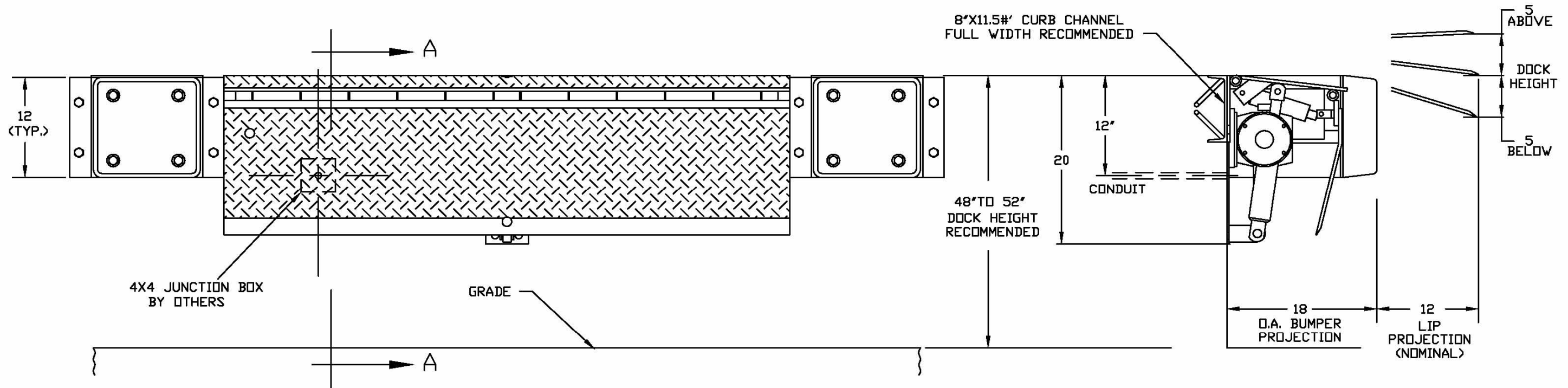
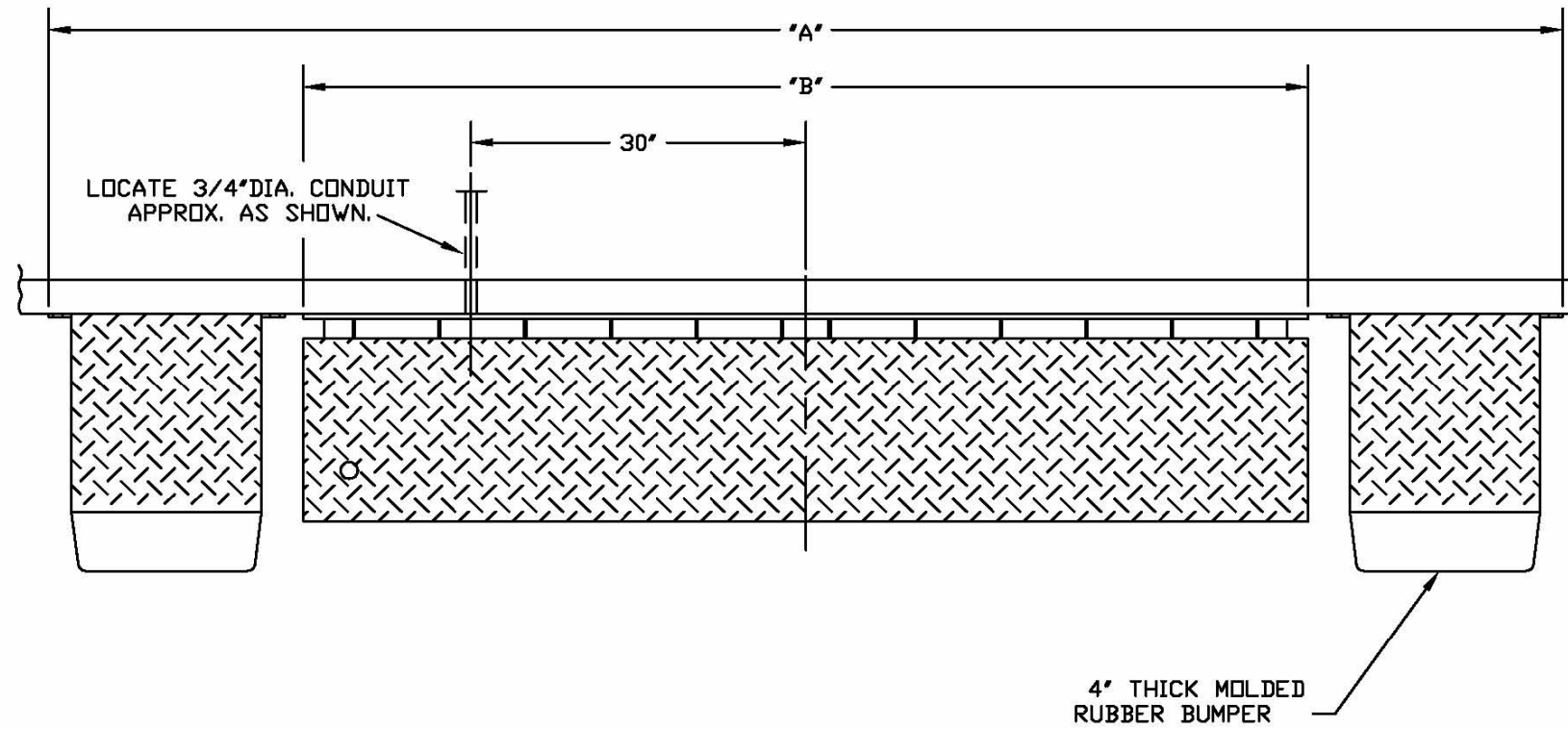

SECTION A-A

Customer:		Certified For Construction:	
Job:		By:	
Location:		Date:	
Number of Units:		Company:	
Model:		City & State:	
Size:			
Represented By:		Voltage:	
Sales Rep:		Drawing #:	

MATERIAL SPECIFICATION		DRAWN		HYDRAULIC EDGE OF DOCK GENERAL ARRANGEMENT
TOLERANCES UNLESS OTHERWISE SPECIFIED DECIMAL DIMENSION FRACTIONAL DIMENSION + 1/16 X OR XX ± 0.003 HOLE DIAMETER +0.003/-0.003 DICK ± 0.003 ANGULAR DIMENSION ± 1 DEG		T.S.B.	DATE	
		6/28/07	SCALE	
		NTS	CHECKED	
		T.S.B.	DRAWING NO/PART NO	
			HED	
			REV	

**McGUIRE**  
 W.B. McGUIRE Co., Inc.