



A Division of Systems, Inc.

HP-H SERIES

Dock Leveler

Owner's Manual



McGUIRE • Division of Systems, Inc. • W194 N11481 McCormick Drive • Germantown, WI 53022
800.624 8473 • fax: 262.257.7399 • www.wbmcguire.com • techservices@docksystemsinc.com

Table of Contents

	Page
Safety	
Recognize Safety Information	1
General Operational Safety Precautions	1
Operational Safety Precautions	2
Maintenance Safety Precautions	4
Safety Decals	5
Introduction	
General Information	6
Dock Leveler Stock Specifications	6
Component Identification	7
Theory	7
Installation	
Prepare Pit	8
Prepare Dock Leveler	9
Install Dock Leveler	10
Install Control Panel and Wiring	16
Put New Leveler Into Service	17
Operation	
Operating Instructions	18
Ramp Loading/Unloading Instructions	19
End Loading/Unloading Instructions	20
Maintenance	
Service Dock Leveler Safely	21
Periodic Maintenance	22
Adjustments	
Hydraulic Schematic	24
Adjust Main System Pressure	25
Adjust Auto Return To Dock (ARTD) Below Dock Control	26
Adjust Down Speed and Lip Extension	28
Electrical	
Signal Phase	30
Three Phase	32
Signal Phase Control Box	36
Three Phase Control Box	38
Troubleshooting	
Troubleshooting	40
Parts	
Frame and Platform	44
Hydraulic Components	48
Weather Seal, Rubber Style and Brush Style	50
Full Range Toeguards	50
Power Pack Assembly	51
Miscellaneous	
Notes	52
Customer Information	53
Warranty	Back Cover

Recognize Safety Information

Safety-Alert Symbol



The Safety-Alert Symbol identifies important safety messages on equipment, safety signs, in manuals, or elsewhere. When you see this symbol, be alert to the possibility of personal injury or death. Follow the instructions in the safety message.

DANGER

The use of the word DANGER signifies the presence of an extreme hazard or unsafe practice which will most likely result in severe injury or death.

WARNING

The use of the word WARNING signifies the presence of a serious hazard or unsafe practice which may result in serious injury or death.

CAUTION

The use of the word CAUTION signifies possible hazard or unsafe practice which could result in personal injury.

IMPORTANT

The use of the word IMPORTANT is to draw attention to a procedure that needs to be followed to prevent machine damage.

General Operational Safety Precautions

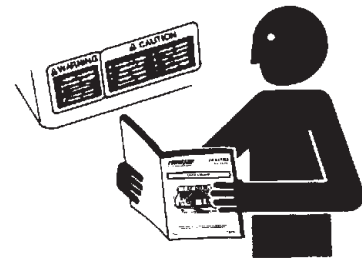

Read and understand the operating instructions and become thoroughly familiar with the equipment and its controls before operating the dock leveler.

Never operate a dock leveler while a safety device or guard is removed or disconnected.

Never remove DANGER, WARNING, or CAUTION signs or decals on the equipment unless replacing them.

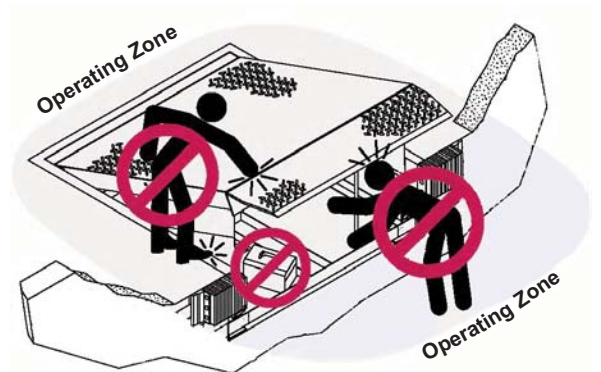

Do not start the equipment until all unauthorized personnel in the area have been warned and have moved outside the operating zone.

Remove any tools or foreign objects from the operating zone before starting.

Keep the operating zone free of obstacles that could cause a person to trip or fall.

SAFETY

Operational Safety Precautions



Learn the safe way to operate this equipment. Read and understand the manufacturer's instructions. If you have any questions, ask your supervisor.



DANGER



Stay clear of dock leveling device when freight carrier is entering or leaving area.



Do not move or use the dock leveling device if anyone is under or in front of it.



Keep hands and feet clear of pinch points. Avoid putting any part of your body near moving parts.



WARNING



Chock/restrain all freight carriers. Never remove the wheel chocks until loading or unloading is finished and truck driver has been given permission to drive away.



Do not use a broken or damage dock leveling device. Make sure proper service and maintenance procedures have been performed before using.

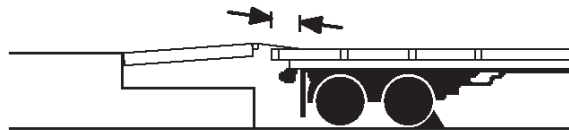

Make sure lip overlaps onto trailer at least 4 in. (102 mm).

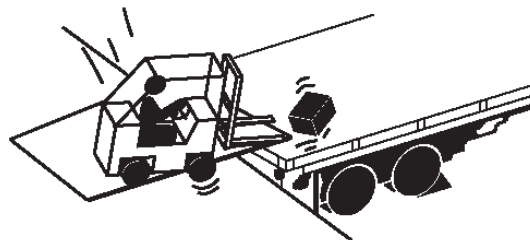

Keep a safe distance from both side edges.

WARNING

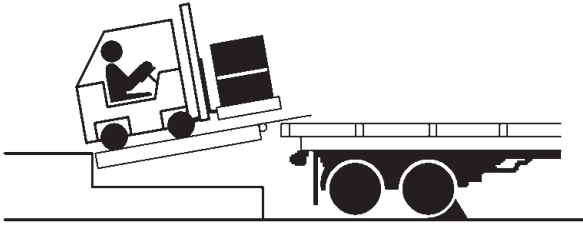

Do not use dock leveling device if freight carrier is too high or too low.

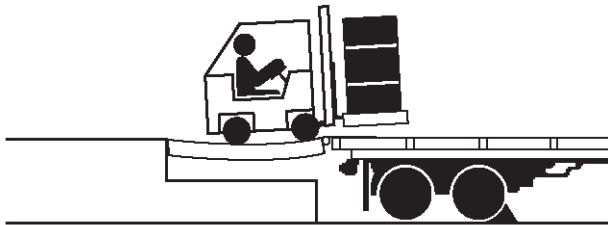

Do not overload the dock leveling device.

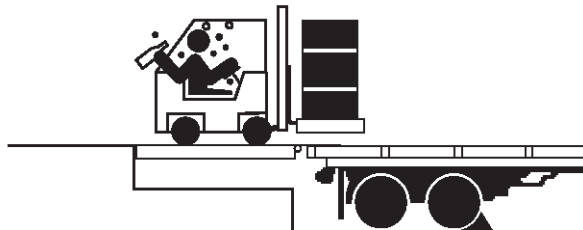

Do not operate any equipment while under the influence of alcohol or drugs.

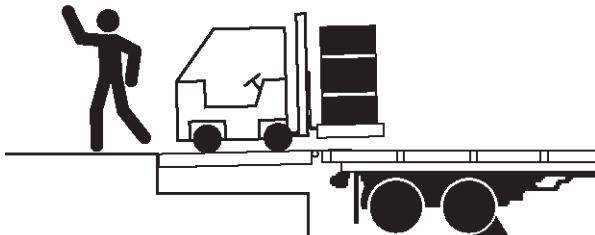

Do not leave equipment or material unattended on dock leveling device.

SAFETY

Maintenance Safety Precautions

DANGER

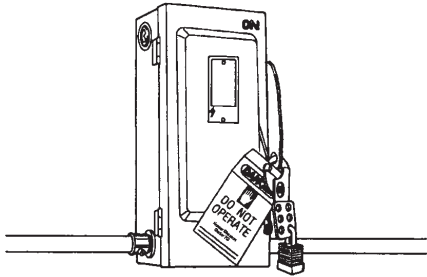

Hydraulic and electrical power must be OFF when servicing the equipment. For maximum protection, use an OSHA approved locking device to lock out all power sources. Only the person servicing the equipment should have the key to unlock the device.

CAUTION



Always post safety warnings and barricade the work area at dock level and ground level to prevent unauthorized use of the unit before maintenance is complete.

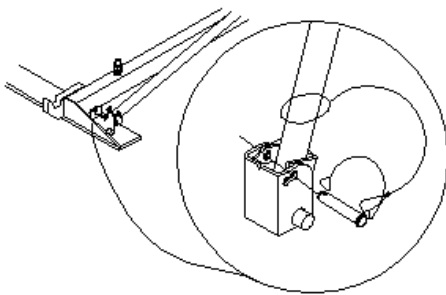

The maintenance prop must be in the upright "service" position when working under the dock leveler. For maximum protection, use an OSHA approved locking device to lock the maintenance prop in the service position. Only the person servicing the equipment should have the key to unlock the device.

WARNING

ALWAYS disconnect electrical power source and ground wire before welding on dock leveler.

DO NOT ground welding equipment to any hydraulic or electrical components of the dock leveler. Always ground to the dock leveler frame.

Failure to follow these instructions may result in damage to dock leveler and/or serious personal injury or death.

WARNING

DO NOT grind or weld if hydraulic fluid or other flammable liquid is present on the surface to be ground or welded

DO NOT grind or weld if uncontained hydraulic fluid or other flammable liquid is present. Stray sparks can ignite spills or leaks near the work area. Always clean up the oil leaks and spills before proceeding with grinding or welding.

Always keep a fire extinguisher of the proper type nearby when grinding or welding.

Failure to follow these instructions may result in serious personal injury or death.

WARNING



ALWAYS stand clear of dock leveler lip when working in front of the dock leveler. Failure to do this may result in serious personal injury or death.

Safety Decals

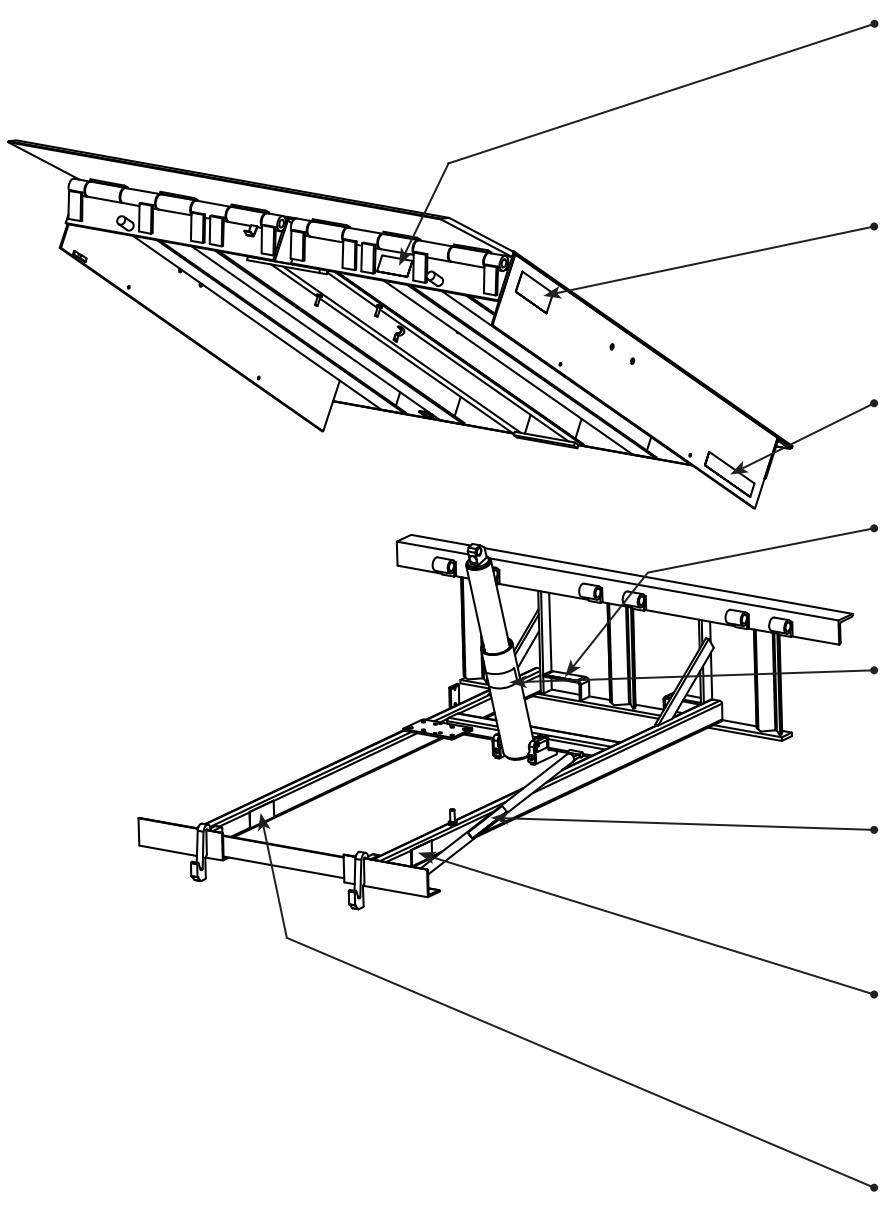
Every 90 days (quarterly) inspect all safety labels and tags to ensure they are on the dock leveler and are easily legible. If any are missing or require replacement, please call 1-800-643-5424 for replacements.



1751-0727

⚠ DANGER	
 <p>CRUSH HAZARD Maintenance prop must support leveler behind bar. Do not force maintenance prop forward of bar to support lip. Refer to owner's/user's manual for proper use. Failure to comply will result in death or serious injury.</p>	 <p style="text-align: right; font-size: small;">1751-0727</p>

1751-0730 (x2)

⚠ DANGER	
 <p>Unsupported dock leveler can lower unexpectedly. Before driving vehicle to leave the dock center:</p> <ul style="list-style-type: none"> • Ensure that no equipment, material or people are on the dock leveler. • Return the dock leveler to its stored position at dock level. <p style="font-size: x-small;">Failure to follow posted instructions can result in death or serious injury.</p>	<p style="text-align: center; font-weight: bold; font-size: small;">SAFETY INFORMATION</p> <p style="font-size: x-small;">Read and understand the safety information in the owner's manual before using the dock leveler. Follow the instructions and warnings in the manual. Do not use the dock leveler if you are not trained or qualified to use it. Do not use the dock leveler if you are not wearing your seat belt. Do not use the dock leveler if you are not wearing your safety glasses. Do not use the dock leveler if you are not wearing your hard hat. Do not use the dock leveler if you are not wearing your safety shoes. Do not use the dock leveler if you are not wearing your safety harness. Do not use the dock leveler if you are not wearing your safety vest. Do not use the dock leveler if you are not wearing your safety helmet. Do not use the dock leveler if you are not wearing your safety goggles. Do not use the dock leveler if you are not wearing your safety gloves. Do not use the dock leveler if you are not wearing your safety boots. Do not use the dock leveler if you are not wearing your safety pants. Do not use the dock leveler if you are not wearing your safety socks. Do not use the dock leveler if you are not wearing your safety underwear. Do not use the dock leveler if you are not wearing your safety pajamas. Do not use the dock leveler if you are not wearing your safety nightgown. Do not use the dock leveler if you are not wearing your safety robe. Do not use the dock leveler if you are not wearing your safety towel. Do not use the dock leveler if you are not wearing your safety blanket. Do not use the dock leveler if you are not wearing your safety quilt. Do not use the dock leveler if you are not wearing your safety duvet. Do not use the dock leveler if you are not wearing your safety sheet. Do not use the dock leveler if you are not wearing your safety pillow. Do not use the dock leveler if you are not wearing your safety blanket. Do not use the dock leveler if you are not wearing your safety quilt. Do not use the dock leveler if you are not wearing your safety duvet. Do not use the dock leveler if you are not wearing your safety sheet. Do not use the dock leveler if you are not wearing your safety pillow.</p>

(decals placed in same position on both sides)

1751-0329 (x2)

	DO NOT FORK THIS SIDE	
---	-----------------------	---

(decals placed in same position on both sides)

1751-0330 (x2)

	FORK HERE
---	-----------

(decals placed in same position on both sides)



1751-0138

⚠ DANGER	
<p>CRUSH HAZARD DO NOT REMOVE hydraulic cylinder until leveler is safely supported by maintenance prop. Refer to owner's/user's manual for proper maintenance procedure. Failure to comply will result in death or serious injury.</p>	

1751-0729

⚠ DANGER	
 <p>CRUSH HAZARD Do not work under dock leveler unless this maintenance prop has been secured in the upright position. See owner's/user's manual for proper procedures. Failure to comply will result in death or serious injury.</p>	 <p style="text-align: right; font-size: x-small;">1751-0729</p>

1751-0731

⚠ DANGER	
 <p>CRUSH HAZARD Open the pin latch and insert through the maintenance prop housing and prop completely. Close the pin latch to secure prop. Use every time dock leveler is serviced. Failure to comply will result in death or serious injury.</p>	 <p style="text-align: right; font-size: x-small;">1751-0731</p>

1751-0726

⚠ DANGER	
 <p>CRUSH HAZARD DO NOT ENTER PIT unless dock leveler is safely supported by maintenance prop. Place barriers on driveway and dock floor to indicate service work being performed. Refer to owner's/user's manual for proper maintenance procedures. Failure to comply will result in death or serious injury.</p>	 <p style="text-align: right; font-size: x-small;">1751-0726</p>

General Information

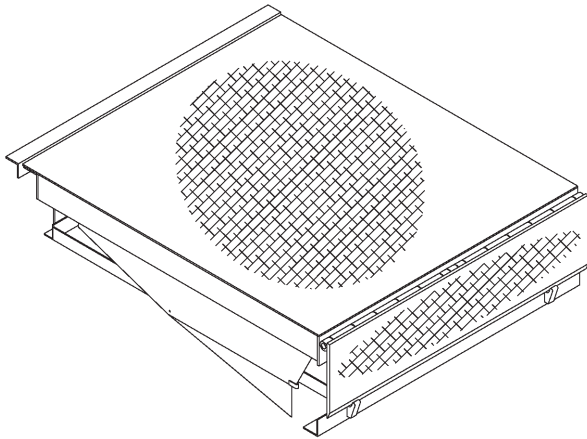

Congratulations on your choice of a McGuire dock leveler. This manual covers the HP/H series hydraulic dock leveler.

Designed by McGuire, to be a marvel of simplicity and efficiency, your dock leveler, when properly installed, will provide many years of trouble-free performance with an absolute minimum of maintenance. Its revolutionary hydraulic system efficiently controls and operates every function. To obtain maximum performance and longest possible use, a simple program of preventive maintenance is recommended.

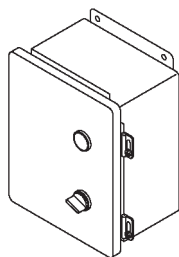

The HP/H series dock leveler comes equipped with an electrical control panel, which allows pushbutton operation of the dock leveler functions. Each HP/H dock leveler unit and control panel has been factory prewired and tested to ensure satisfactory operation.

To illustrate which connections are to be made in the field at installation, electrical drawings are included with each order or by contacting McGuire Technical Services.

Once again, thank you and congratulations on your purchase of a McGuire hydraulic dock leveler.

Dock Leveler Stock Specifications

HP/H dock levelers are available in the following sizes, weight capacities, and options:

Width: HP/H

- 6 ft (1828.8 mm)
- 6-1/2 ft (1981.2 mm)
- 7 ft (2133.6 mm)

Length

- 6 ft (1828.8 mm)
- 8 ft (2438 mm)
- 10 ft (3048 mm)
- 12 ft (3658 mm)

Capacity (CIR*)

- 25,000 lb (11 340 kg)
- 30,000 lb (13 608 kg)
- 35,000 lb (15 876 kg)
- 40,000 lb (18 144 kg)
- 45,000 lb (20 412 kg)
- 55,000 lb (24 948 kg)
- 75,000 lb (34 019 kg)
- 100,000 lb (45 359 kg)

*CIR (Comparative Industry Rating)

Call McGuire, to discuss available voltages, phases and options to meet your specific needs.

INTRODUCTION

Component Identification

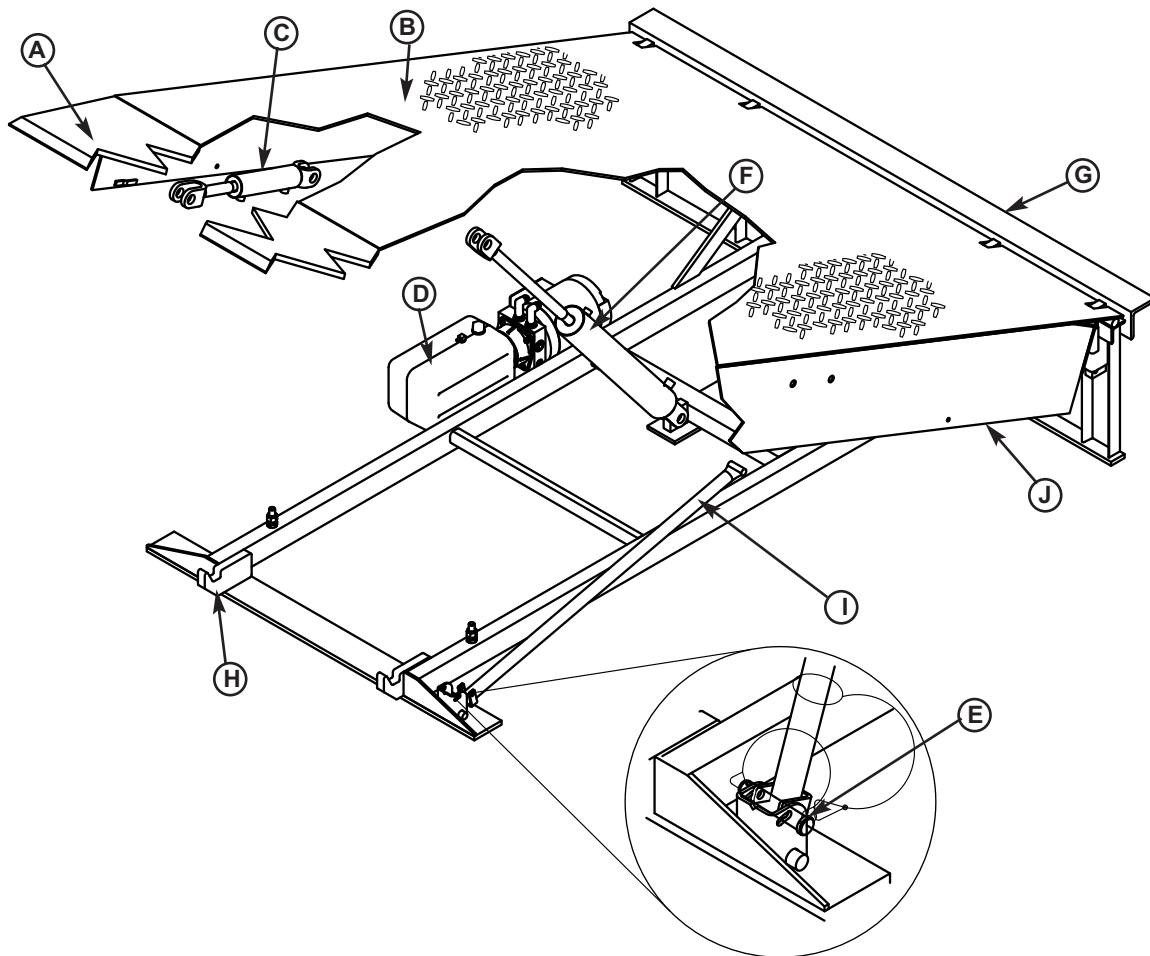

A—Lip
B—Platform
C—Lip Cylinder

D—Powerpack (Motor/Pump/Reservoir)
E—Prop Pin and Clip
F—Platform Cylinder

G—Main Frame
H—Lip Keepers (2 used)
I—Maintenance Prop

J—Toe Guard (2 used)

THEORY

The HP/H dock leveler uses hydraulics and one-button operation for ease of use.

Platform (B) is raised by pushing and holding the RAISE button (K). This activates an electric motor (D) which, in turn, drives a hydraulic pump. The hydraulic pump forces oil into the platform cylinder(s) (F), causing the platform to rise. Releasing the RAISE button allows the platform to lower.

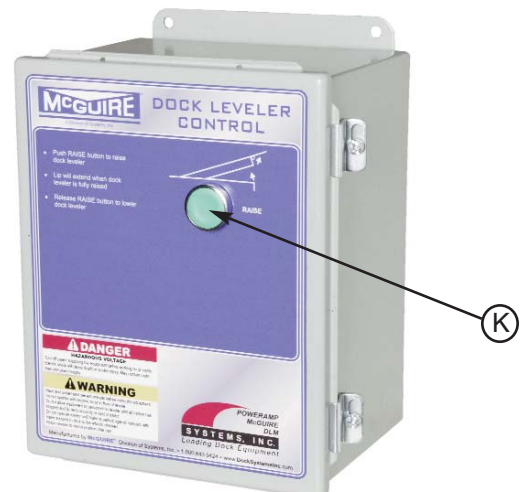

Prepare Pit

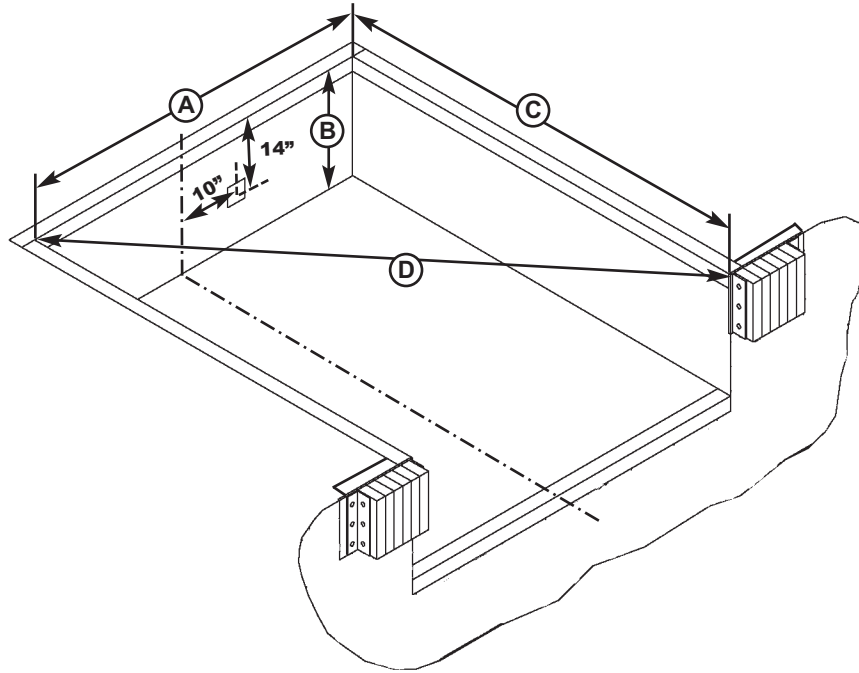

A—Distance (Pit Width)
(Front and Rear)

B—Distance (Dock Floor-to-Pit
Floor) (All Four Corners)

C—Distance (Pit Length)
(Both Sides of Pit)

D—Distance (Pit Corner-to-Corner)
(Top, Bottom, and Both Sides)

WARNING

Post safety warnings and barricade the work area at dock level and ground level to prevent unauthorized use of the dock leveler before installation has been completed.

Failure to follow the installation instructions can result in damage to dock leveler, the facilities, and/or serious personal injury or death.

CAUTION

Only trained installation professionals with the proper equipment should install this product.

IMPORTANT

DO NOT remove the shipping bands around the dock leveler lip until instructed to do so.

Before lowering the dock leveler into the pit, the following must be performed:

1. Remove all debris from the pit and sweep the pit clean.
2. Check the entire dock leveler pit for proper construction according to approved/certified pit drawings. Make sure pit is square by making the following measurements:

- Measure pit width distance (A) at both front and rear of pit.
- Measure dock floor-to-pit floor distance (B) at all four corners.
- Measure pit length distance (C) at both sides.
- Measure corner-to-corner (criss-cross) distance (D) at both sides. Take measurements at dock floor level and at pit floor level.

If any measurement is off by more than 1/8 in. (3.18 mm), contact Systems, Inc. Technical Services before proceeding.

3. Make sure the field junction box for the dock leveler (E) is at the correct location per pit diagrams.

INSTALLATION

Prepare Dock Leveler

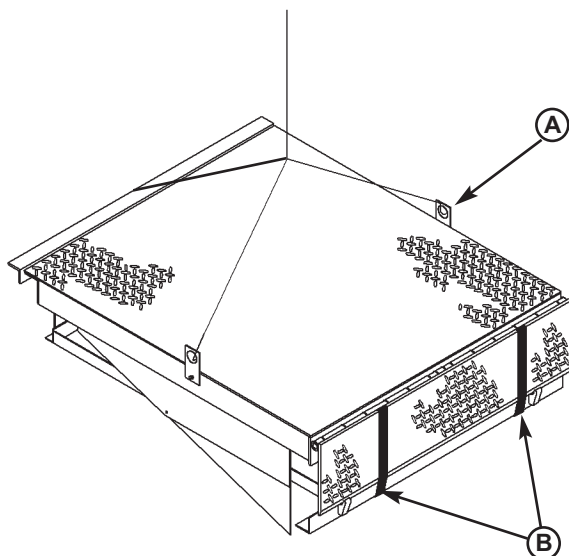

A—Lifting Bracket (2 used)

B—Shipping Bands

McGuire dock levelers are designed with installation in mind. Each unit is shipped with lifting brackets (A) fastened to the platform side joists. **A third sling may be used to install the unit.**

WARNING

The dock leveler is heavy. Use a lifting device and chains with the appropriate lifting capacity and reach.

Always use the lifting brackets provided with the unit whenever lowering or lifting a dock leveler into or out of a pit.

Failure to follow these instructions may result in damage to dock leveler and/or serious personal injury or death.

IMPORTANT

DO NOT remove the shipping bands (B) around the platform lip and leveler frame at this time. The shipping bands are needed to hold the leveler together during the installation process. **Turn to page 15 for front pick up.**

1. Remove any control panel and bumpers that may be banded to the frame of the dock leveler. DO NOT remove the shipping bands (B) around the platform lip and leveler frame at this time.

IMPORTANT

DO NOT overtighten the lifting bracket hardware. Overtightening can damage the weather seal, if equipped.

NOTE: Overall width of platform and lifting brackets (A) must be kept to a minimum to prevent interference between the lifting brackets and the pit walls as the dock leveler is lowered into the pit.

2. Make sure the mounting hardware of lifting brackets (A) is snug. The brackets should pivot relatively freely on the mounting cap screw. DO NOT overtighten.
3. Attach lifting chains to lifting brackets (A) and to a lifting device (i.e., hoist or fork truck) having the appropriate lifting capacity and reach.
4. Remove shipping pallet, if present, before putting the dock leveler into the pit.

INSTALLATION

Install Dock Leveler

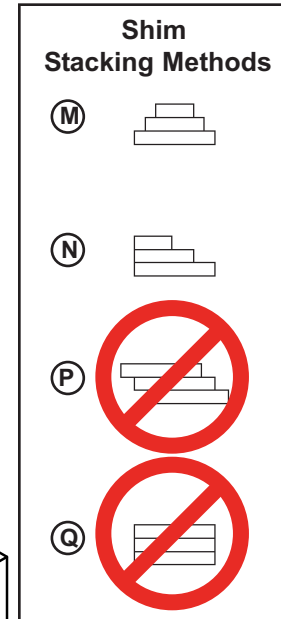
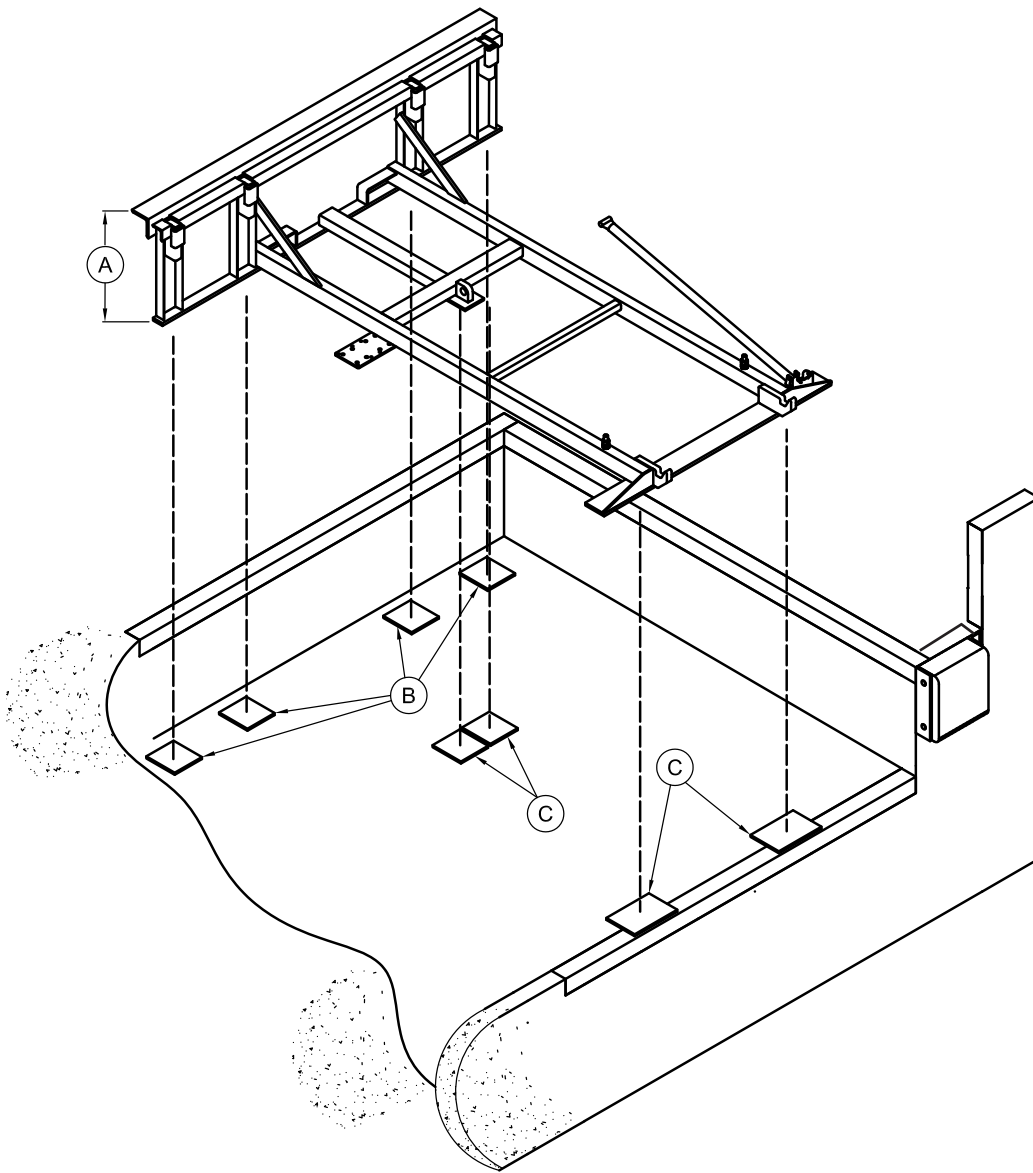

- A—Distance (Leveler Frame Height)
- B—Shim Locations (Under Rear Vertical Supports)
- C—Shim Location (Under Maintenance Prop, Lip keepers, Main cylinder)
- D—Dock Floor
- E—Rear Pit Curb Angle
- F—String
- G—Rear Hinge Frame Angle
- H—Distance (Dock Floor-to-Pit Floor)
- J—Distance (Top of Shim Stack-to-Dock Floor)
- K—Shim Stack
- L—Dock Leveler Frame
- M—Pyramid (Preferred)
- N—Stepped (Acceptable)
- P—Offset (Not Acceptable)
- Q—Straight (Not Acceptable)

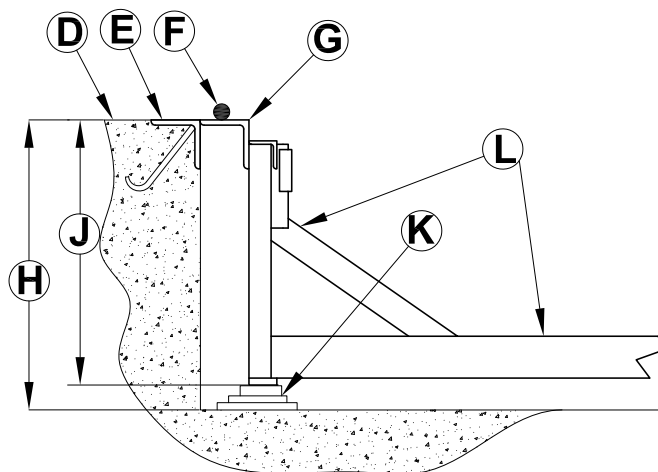

NOTE: McGuire dock levelers are designed with a nominal 1/2 in. (12.7 mm) shimming distance to allow for pit inconsistencies.

1. Determine height of shim stack (K) for each shim location (B) by performing the following:
 - a. Measure leveler frame height distance (A).
 - b. Measure dock floor-to-pit floor distance (H) at each shim location (B). Write down the dimensions obtained at each location.
 - c. Subtract distance (A) from distance (H) to obtain the shim height. Repeat for each shim location.

IMPORTANT

The minimum size of the shim that contacts the leveler frame (i.e., the top shim of each shim stack) must be at least 4-1/2 x 4-1/2 in. (114.3 x 114.3 mm) to support the full width of the frame rail and to provide a shelf for a fillet weld.

Use the thickest shim stock possible for stability and weld penetration purposes. DO NOT use multiple layers of 1/8 in. (3.18 mm) or thinner shim stock.

2. Using the results obtained in step 1, create the individual shim stacks on the pit floor at locations (B). Build each shim stack (K) using the pyramid method (M) (preferred) or stepped method (N) with the top shim having a minimum size of 4-1/2 x 4-1/2 in. (114.3 x 114.3 mm) and each successive lower shim being larger so the shims can be welded together using a fillet weld. DO NOT use offset method (P) or straight method (Q).

NOTE: To assist in obtaining an accurate measurement of distance (J), use a string (F) pulled tight across the pit opening, directly over the shim locations.

3. Verify that each shim stack is at the correct height by measuring distance (J) [top of shim stack (K) to dock floor]. Distance (J) must equal the dock leveler height (A).

4. For all HP/H models, put a minimum 1/4 in. (6.6 mm) thick shim at locations (B and C) .

NOTE: A 1/4 in. (6.6 mm) thick shim at locations (B and C) is used only as a starting point. The final shim stack height will be determined after dock leveler is lowered into the pit.

WARNING

The dock leveler is heavy. Use chains and a lifting device with the appropriate lifting capacity and reach. Failure to do so may result in damage to dock leveler and/or serious personal injury or death.

5. Using an appropriate lifting device connected to the lifting brackets, lower dock leveler into the pit so rear hinge frame angle (G) is tight against rear pit curb angle (E) across full width of the leveler frame.
6. Allow rear of dock leveler to rest on the rear shims while keeping the front of the dock leveler level with the dock floor.
7. For all HP/H models, add shims at front shim locations (C) so front of dock leveler will stay level with dock floor when leveler is resting fully on shims.

INSTALLATION

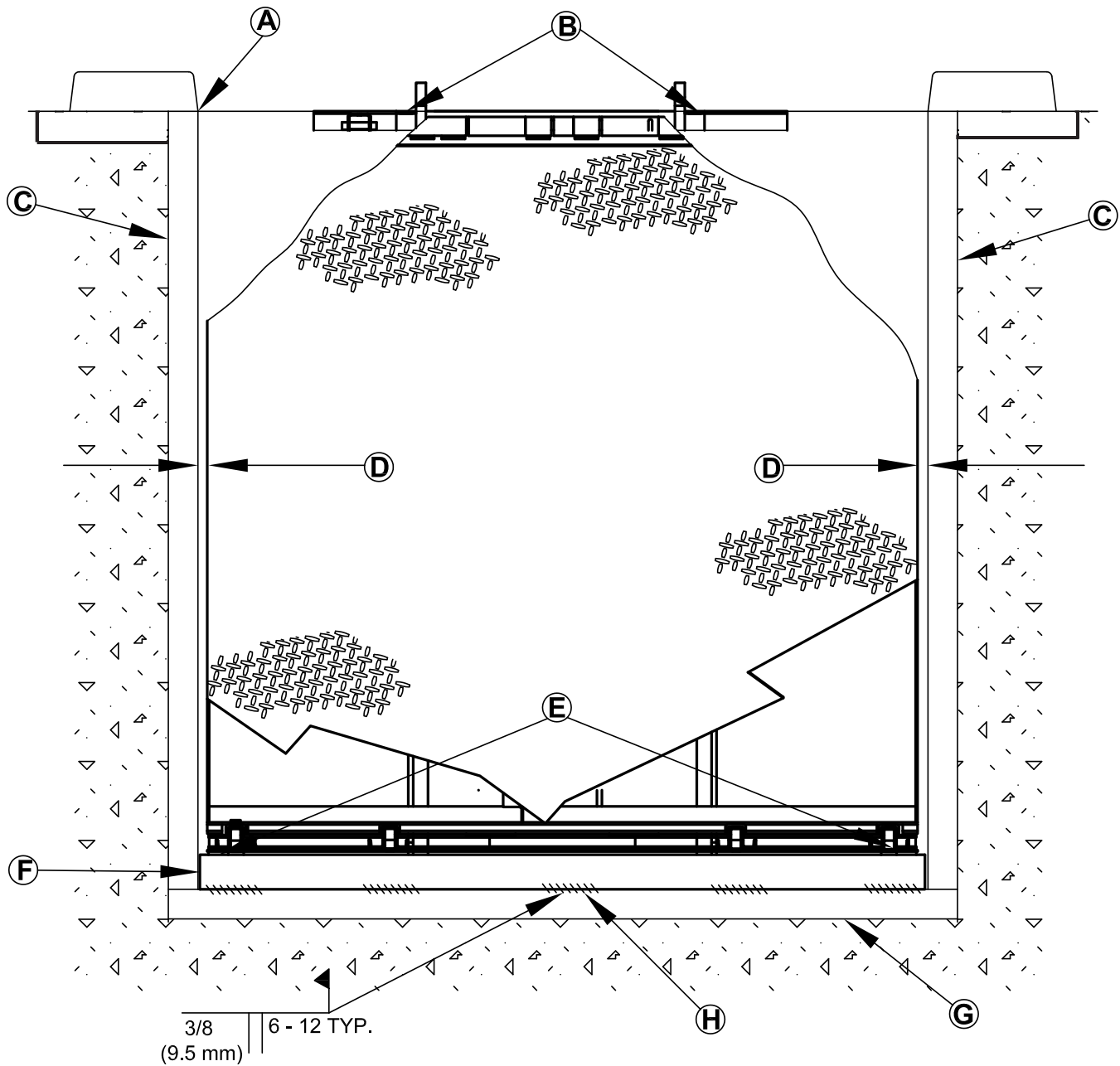

A—Front of Dock Pit
B—Dock Leveler Frame

C—Side Pit Curb Angle
D—Gap [3/4 in. (19 mm)
Minimum]

E—Pry Locations
F—Rear Hinge Frame Angle

G—Rear Pit Curb Angle
H—Flare Bevel Weld, Typical
(To Fit Spacing)

8. With rear hinge frame angle (F) tight against rear pit curb angle (G), perform/check the following:

- Pry between the platform and rear hinge frame angle at locations (E) to make sure rear edge of platform is parallel to the rear hinge frame angle (F).
- Gap (D) must exist equally along both sides of leveler so weather seal (if equipped) will not bind during dock leveler operation.

9. If gap (D) cannot be obtained equally at both sides of leveler, grind or add material at the rear edge of rear hinge frame angle (F) as needed.

10. Allow the dock leveler to rest fully on the shim stacks. Check that a smooth and level transition exists between the dock floor and the dock leveler platform. Add or remove shims as necessary until a smooth transition is obtained.

11. If leveler cannot be squared and/or made level as instructed in steps 8—10, contact Systems, Inc. Technical Services.



WARNING

DO NOT grind or weld if hydraulic fluid or other flammable liquid is present on the surface to be ground or welded.

DO NOT grind or weld if uncontained hydraulic fluid or other flammable liquid is present. Stray sparks can ignite spills or leaks near the work area. Always clean up the oil leaks and spills before proceeding with grinding or welding.

Always keep a fire extinguisher of the proper type nearby when grinding or welding.

Failure to follow these instructions may result in serious personal injury or death.

IMPORTANT

DO NOT connect the dock leveler electrical wiring and ground connections until all welding has been completed.

DO NOT ground welding equipment to any hydraulic or electrical components of the dock leveler. Always ground welding equipment to the dock leveler frame, NEVER to the platform.

Failure to follow these instructions may damage the motor, hoist cylinder, wiring, and/or control panel.

NOTE: The illustration on the previous page shows a typical weld pattern. The weld pattern will vary slightly depending on size of dock leveler.

IMPORTANT

DO NOT weld continuously along the full length of the rear hinge frame angle. This can put unnecessary stress on the leveler components, causing the leveler to malfunction and shorten the lifespan of the affected components.

11. With the rear hinge frame angle (F) tight against the rear pit curb angle (G), weld the rear hinge frame angle (F) to the rear pit curb angle (G) using a 3/8 in. (9.5 mm) flare bevel skip weld —each weld being 6 in. (152 mm) long.

Start at each end with a 6 in. (152 mm) long weld. Space all the other welds out evenly leaving approximately 6 in. (152 mm) space between each weld.

12. Weld front of dock leveler frame (B) to shims located under the keepers, then weld the shims to the front pit curb steel.
13. With leveler welded into place, remove the shipping bands from around lip and leveler frame.



WARNING

If the platform is raised using an external lifting device or the hydraulic system is opened to atmosphere, air will enter into the hydraulic system.

Whenever this happens, always cycle the leveler at least 4 times using the leveler's own hydraulic power system before allowing the leveler to be put into service. This is to make sure all air is purged from the hydraulic cylinders. Failure to do this may result in serious personal injury or death.

INSTALLATION

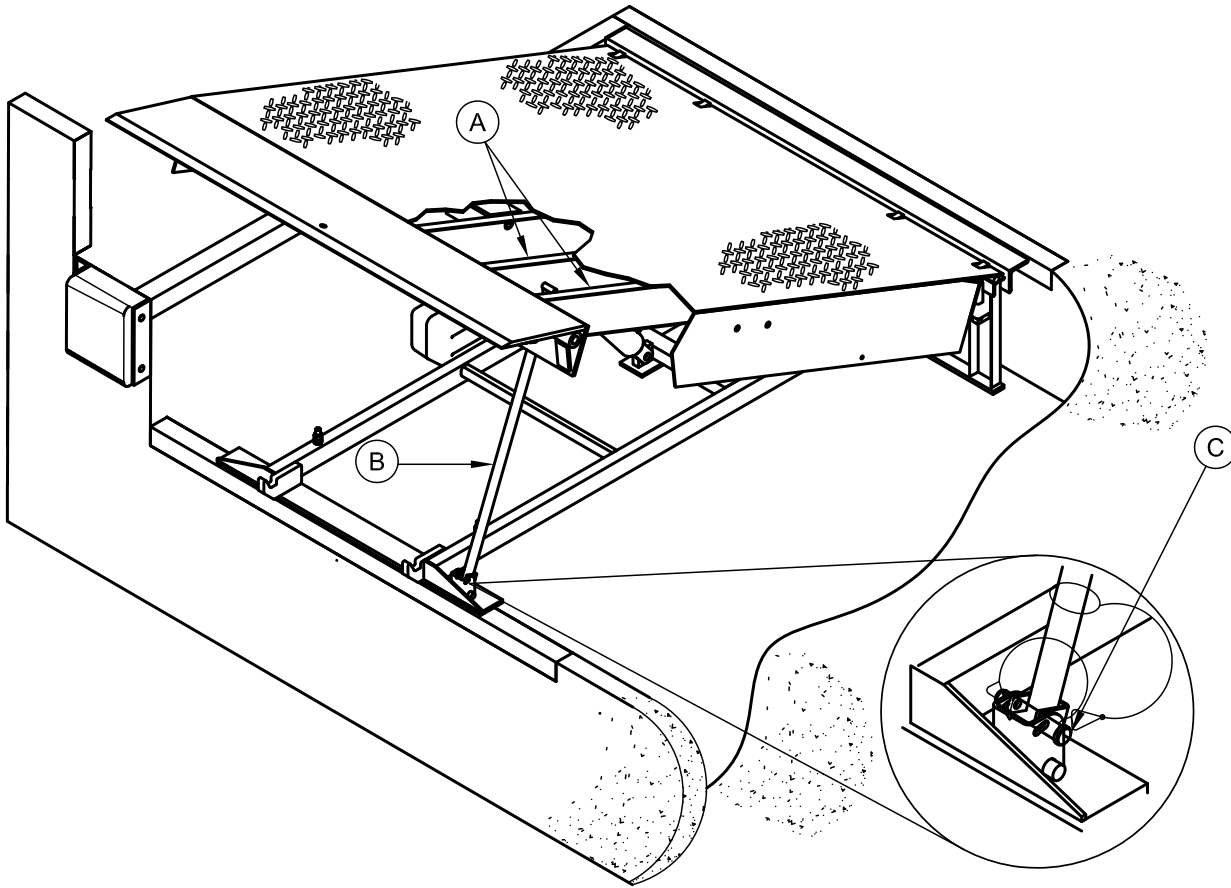

A—Platform Joists

B—Platform Maintenance Prop

C—Prop Pin and Clip

14. Using an external lifting device (i.e., crane or fork truck) attached to the platform lifting brackets, slowly raise the platform. Check for binding as platform is being raised.
15. If binding occurs, lower the platform. Reposition leveler and/or add or remove shims as necessary. Slowly raise platform again. If platform still binds, contact Systems, Inc. Technical Services for further instructions.
16. All HP/H models:
 - a. Install shims under maintenance prop (B) where prop attaches to leveler frame. Make sure prop is solidly shimmed.
 - b. Using the appropriate lifting device, attached to the platform lifting lugs, slowly raise the dock to the fully open position.

CAUTION

Two people are required to engage the maintenance prop: one person to operate the lifting device, the other person to engage the maintenance prop.

WARNING

DO NOT use the maintenance prop to support the raised platform until the maintenance prop has been properly shimmed and welded. The shims must be welded to each other, the leveler frame, and to the front pit curb steel. Failure to do this may result in serious personal injury or death.

- c. Raise maintenance prop (B) to the service (upright) position and lock prop in this position using an OSHA approved locking device. (Supplied by others)
- d. Proceed to step 18.

WARNING

Make sure the platform is properly supported in the raised position before entering the pit to finish weld the shims. Failure to do this may result in serious personal injury or death.

18. All model levelers: Install shims at locations (B)(C) (Ref. page 10) using the pyramid or stepped shimming method. Both platform cylinder trunnions must be solidly shimmed the entire length of the trunnion. Make sure the trunnions are level from side-to-side as well as from front-to-back.
19. Finish weld all shims using a fillet weld.
 - Weld all shims within each shim stack to each other, then weld the shim stack to the leveler frame.
 - Weld the front leveler frame shim stacks to the front pit curb steel.
20. When all welding has been completed, paint all the welds and shims.

NOTE:

To pick up unit from the front, move forks closer together and slide over the frame and under the cross member. It may be necessary to unband the unit to gain access to the front, by lifting the lip up then sliding the forks under the cross member. (Ref: page 9)

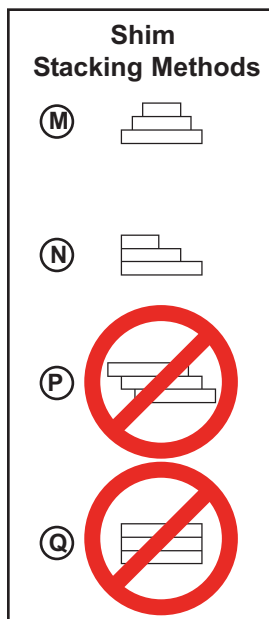

Front Pick Up

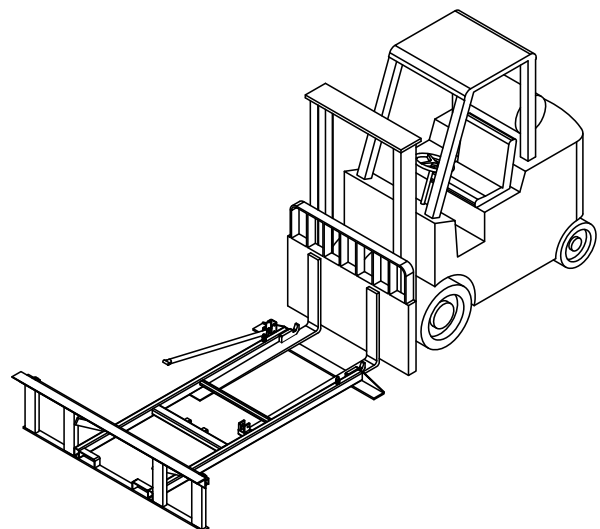

Rear Pick Up

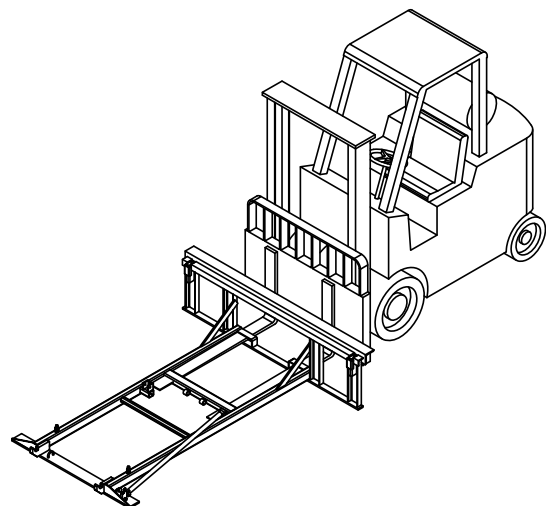

*For left/right orientation of dock leveler, see inside back cover of this manual.

INSTALLATION

Install Control Panel and Wiring

WARNING

The electrical power must be OFF prior to electrical installation. For maximum protection, use an OSHA approved locking device to lock out all power sources. Only the person installing the equipment should have the key to unlock the power source.

Failure to follow these instructions may result in serious personal injury or death.

WARNING

DO NOT make any final electrical connections until all welding has been completed. Failure to do this may result in serious personal injury or death.

CAUTION

All electrical work—including the installation of the disconnect panel, control panel, and final connections to the pit junction box—must be performed by a certified electrician and conform to all local and applicable national codes.

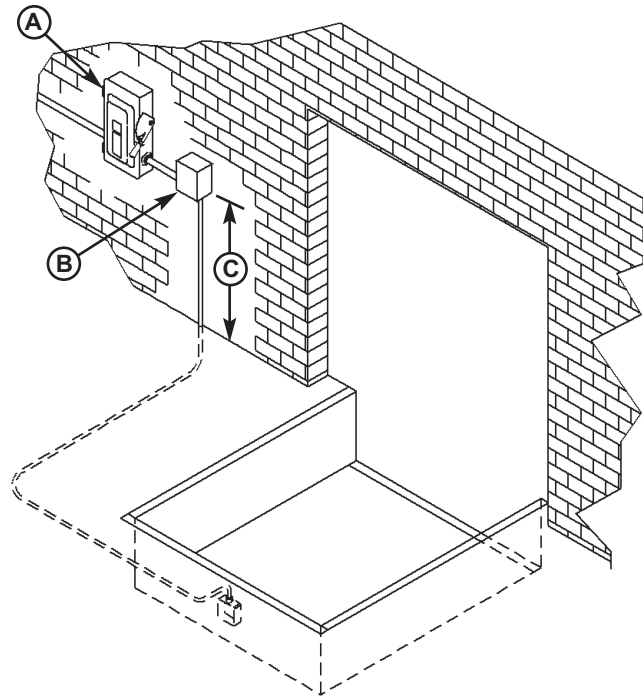

A—Disconnect Panel (provided by others)
B—Control Panel C—Distance, 48 in. (14 630 mm), minimum.

1. Mount the pushbutton control panel (B) so bottom of control panel-to-dock floor distance (C) is a minimum 48 in. (1219.2 mm).
2. Install electrical disconnect panel (A) if not already installed.
3. Install and connect the control wiring.
4. Connect the dock leveler power cable to the field wires in the pit junction box. Refer to the electrical drawings supplied with the dock leveler.
5. After all electrical connections in the pit have been made, disengage the maintenance prop and lower the platform using the external lifting device connected to the platform lifting brackets.

Put New Dock Leveler Into Service

1. Disconnect the external lifting device and chains from the lifting brackets.
2. Check that the leveler is flush with the dock floor and that the platform lip contacts both lip keepers evenly.

If an excessive transition exists between the dock floor and leveler and/or lip does not contact both lip keepers evenly, contact Systems, inc. Technical Services for further instructions.

3. Install the dock bumpers as required.
4. Turn the main electrical power ON.



WARNING

Always stand clear of platform lip when working in front of the dock leveler. Serious personal injury or death may result.

5. Raise the leveler platform fully by pushing and holding the RAISE button .

NOTE: The platform of a properly operating dock leveler will automatically stop rising when it reaches its full raised height, at which point, the lip extends. (If the lip does not extend or extend fully, see Platform Rises to Full Height, But Lip Does Not Fully Extend in the Troubleshooting section.)

6. Release the RAISE button to lower the platform. As long as there is no truck present at the dock, the platform will lower to the full below-dock position with the lip extended.

NOTE: If a truck is present, the platform will lower until the lip rests on the truck/trailer bed. (See Operating Instructions in Operation section.)

7. When the platform lowers to the full below-dock position, push and hold the RAISE button until the lip retracts and platform rises just enough to have the lip clear the lip keepers, then release the RAISE button to allow the platform to lower to the cross-traffic (stored) position (lip engages lip keepers).

NOTE: For dock levelers equipped with Auto Return To Dock (ARTD), the platform will automatically return to the cross-traffic position if the ARTD is in NORMAL mode. When the platform is about 1.00 inch from the full below-dock position, the platform will automatically rise to the cross-traffic position. (See below dock servicing and end loading for additional instructions)

8. Perform steps 5–7 at least four times to purge any air that may be in the hydraulic system and to ensure proper operation.



CAUTION

Unless the dock leveler is equipped with a tethered remote, two people are required to engage the maintenance prop: one person to operate the unit, the other person to engage the maintenance prop.

9. Raise the platform fully. Hold the platform at this position using the RAISE button and move the maintenance prop to the service (upright) position. Release the RAISE button to allow the platform to lower until it is resting on the maintenance prop.
10. With the maintenance prop supporting the platform, remove the lifting brackets on both sides of the unit.
11. Push and hold the RAISE button until the maintenance prop drops to its stored position. Release the RAISE button and allow the platform to lower fully.
12. Perform step 7 if not equipped with ARTD.

OPERATION

DANGER

Stay clear of dock leveler when freight carrier is entering or leaving dock area.

DO NOT move or use the dock leveler if anyone is under or in front of leveler.

Keep hands and feet clear of pinch points. Avoid putting any part of your body near moving parts.

Failure to follow these instructions may result in severe personal injury or death.

WARNING

Only trained personnel should operate the dock leveler.

DO NOT use a broken or damaged dock leveler. Make sure proper service and maintenance procedures have been performed on leveler before using.

Truck/trailer wheels must be chocked unless the truck restraint is used. Never remove the wheel chocks until loading/unloading is finished and truck driver has been given permission to leave.

Make sure platform lip rests on the truck/trailer bed with at least 4 in. (102 mm) of overlap.

Maintain a safe distance from side edges of leveler during the loading/unloading process.

Failure to follow these instructions may result in serious personal injury or death.

WARNING

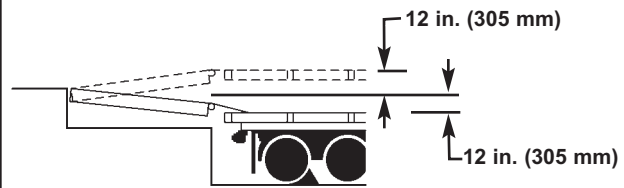

The HP/H hydraulic dock leveler is designed to compensate for a maximum ± 12 in.* (305 mm) of height difference between the loading dock and the truck bed. DO NOT use the dock leveler if the truck/trailer bed is more than 12 in. (305 mm) higher or lower than the dock floor.

*service height may vary with design specifications

DO NOT overload the dock leveler.

DO NOT operate any equipment while under the influence of alcohol or drugs.

DO NOT leave equipment or material unattended on the dock leveler.

Failure to follow these instructions may result in personal injury and/or damage to equipment.

Operating Instructions—Continued

Ramp Loading/Unloading Instructions

NOTE: If end unloading is required, see End Loading/Unloading Instructions on page 20.

For ramp loading or unloading, the HP/H dock leveler can be operated by using the RAISE button on the control panel.

1. Check to make sure truck/trailer is positioned squarely against dock bumpers.
2. Instruct driver to remain at the dock until the loading or unloading process has been completed.
3. Chock the truck/trailer wheels or use the truck restraint if available.

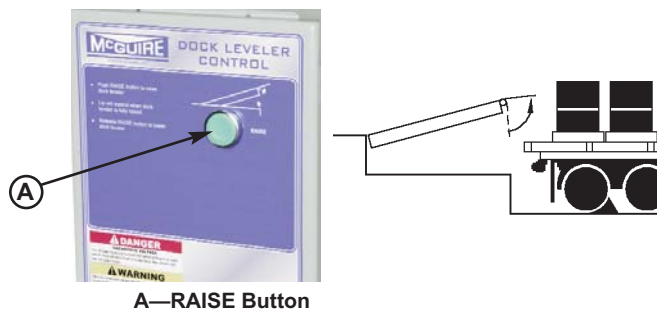

A—RAISE Button

4. Extend the platform lip onto truck/trailer as follows:
 - a. Raise the platform by pushing and holding RAISE button .
 - b. Hold the RAISE button until the lip is fully extended, then release the RAISE button. The platform will lower until the lip is resting on the truck/trailer bed.
 - c. Make sure that the lip is fully extended and supported on the truck/trailer along the entire width of the platform with at least 4 in. (102 mm) of lip overlapping the truck bed.

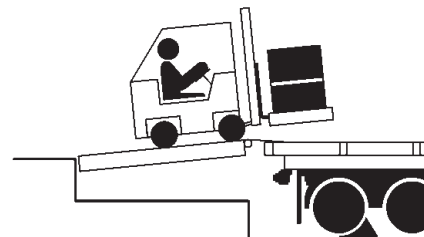

5. Proceed with loading or unloading the truck/trailer.
6. If end loading is necessary, see End Loading/Unloading Instructions on page 20.

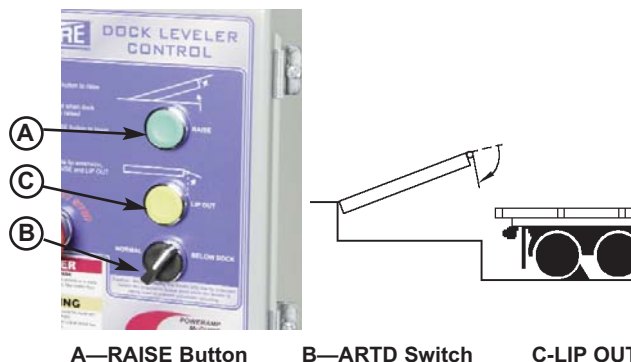

A—RAISE Button

B—ARTD Switch

C—LIP OUT

7. When loading or unloading is finished, raise the platform by pushing and holding RAISE button (A) .

Hold the RAISE button until the lip folds enough to clear the truck/trailer bed, then release the RAISE button. The lip will fold and the platform will return to the cross-traffic position.

8. Remove chocks from truck/trailer wheels or release the truck restraint if used.
9. Indicate to driver that truck may leave the dock.

OPERATION

Operating Instructions—Continued

End Loading/Unloading Instructions

NOTE: If ramp loading is required, see Ramp Loading/Unloading Instructions on page 19.

End loading or unloading can be done with the dock at the cross-traffic position or below-dock position, depending on the height of the truck/trailer bed.

1. Check to make sure truck/trailer is positioned squarely against dock bumpers.
2. Instruct driver to remain at the dock until the loading or unloading process has been completed.
3. Chock the truck/trailer wheels or use the truck restraint if available.

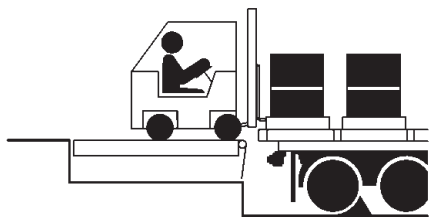

End Loading/Unloading—Platform at Cross-Traffic Position.

4. If truck/trailer bed is at or above dock floor level, leave leveler at the cross-traffic position and proceed with loading or unloading.

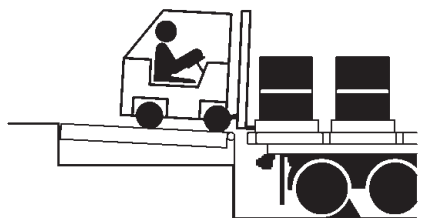

End Loading/Unloading—Platform at Below-Dock Position.

5. If truck/trailer bed is below the dock floor level, and the dock is equipped with the optional lip-out button, perform steps 6–12.

CAUTION

Whenever end loading or unloading with the platform in the below-dock position, make sure the ARTD switch is in the OFF position. DO NOT turn the ARTD switch to the ON position until end loading or unloading is finished.

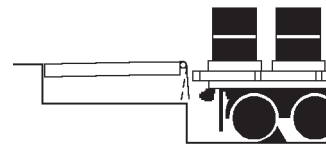
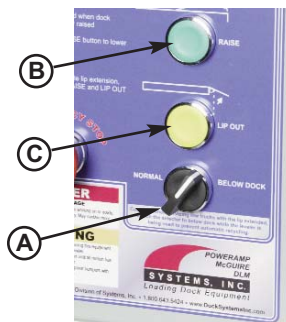

A—ARTD Switch

6. Turn the ARTD switch (A) on the control panel to the BELOW DOCK position, if equipped.
7. Push the Raise button (B) to the platform just enough to clear the lip keepers.
8. When the platform lip clears the lip keepers, push the Lip-Out button (C) just long enough to clear the lip keepers. Release Lip-Out button. The platform will drift down to the full below-dock position.
9. Proceed with loading or unloading.

NOTE: When end unloading is finished and access to the rest of the truck/trailer is still required, the platform lip will need to be extended. See Ramp Loading/Unloading Instructions on page 19 for further instructions.

10. When the loading or unloading is finished, return the dock leveler platform to the cross-traffic (stored) position by performing one of the following:

- Turn the ARTD switch (A) to the NORMAL position, if equipped. The platform will automatically rise to the cross-traffic position.

OR

- Push the Raise button (B) until the lip clears the lip keepers. Release Raise button, leveler will return to the stored or cross traffic position.
11. Remove chocks from truck/trailer wheels or release the truck restraint if used.
 12. Indicate to the driver that the truck may leave the dock.

Service Dock Leveler Safely

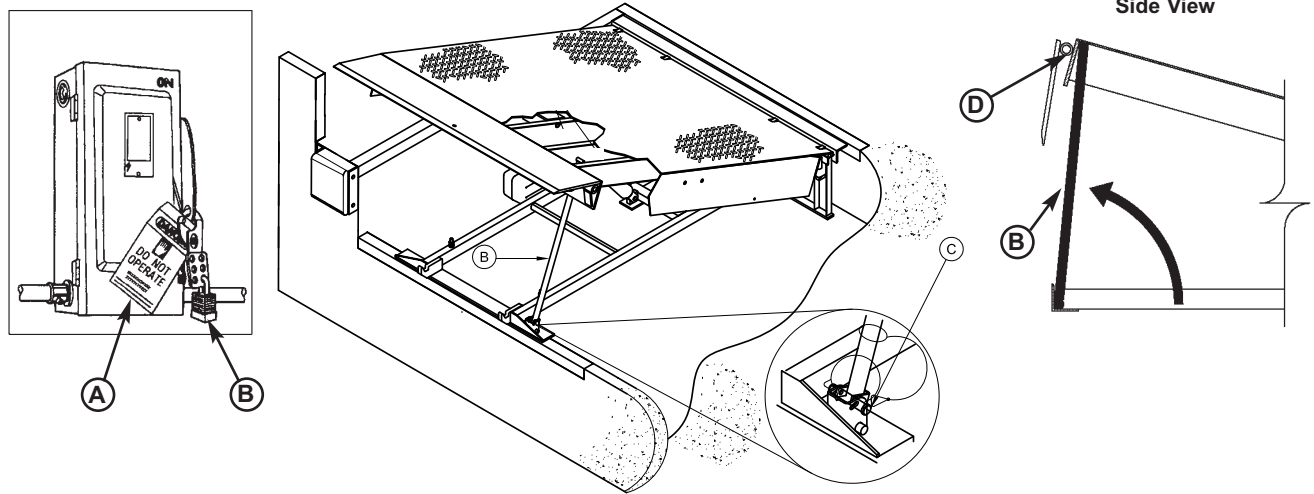

A—Tagout Device
B—Lockout Device

B—Maintenance Prop

C—Prop Pin and Clip

D—Header Plate

Note: Lockout & Tagout Devices are not supplied with leveler. They are to be supplied by others.

WARNING

When service under the dock leveler is required, always lock all electrical disconnects in the OFF position after raising the platform and engaging the maintenance prop. Failure to do this may result in serious personal injury or death.

WARNING

Always post safety warnings and barricade the work area at dock level and ground level to prevent unauthorized use of the dock leveler before maintenance is complete. Failure to do this may result in serious personal injury or death.

WARNING

Always stand clear of the dock leveler lip when working in front of the dock leveler.

The maintenance prop **MUST** be in the service position when working under the dock leveler. For maximum protection, use an OSHA approved locking device to lock the maintenance prop in the service position. Only the person servicing the equipment should have the key to unlock the maintenance prop.

Unless the dock leveler is equipped with a tethered remote, two people are required to engage the maintenance prop: one person to operate the unit, the other person to engage the maintenance prop.

Failure to follow these instructions may result in serious personal injury or death.

Whenever maintenance is to be performed under the dock leveler platform, support the platform with maintenance prop (B). Position the maintenance prop behind front header plate (D) while staying clear of the lip. Lock the maintenance prop in the service (upright) position using an OSHA approved lockout device* (B) and tagout device* (A).

Whenever servicing the dock leveler, lock the electrical power disconnect in the OFF position. Use only an OSHA approved lockout device* (B) and tagout device (A).

Only the person servicing the equipment should have the capability to remove the lockout devices. The tagout devices* must inform that repairs are in process and clearly state who is responsible for the lockout condition.

* Refer to OSHA regulation 1910.147.

MAINTENANCE

Periodic Maintenance

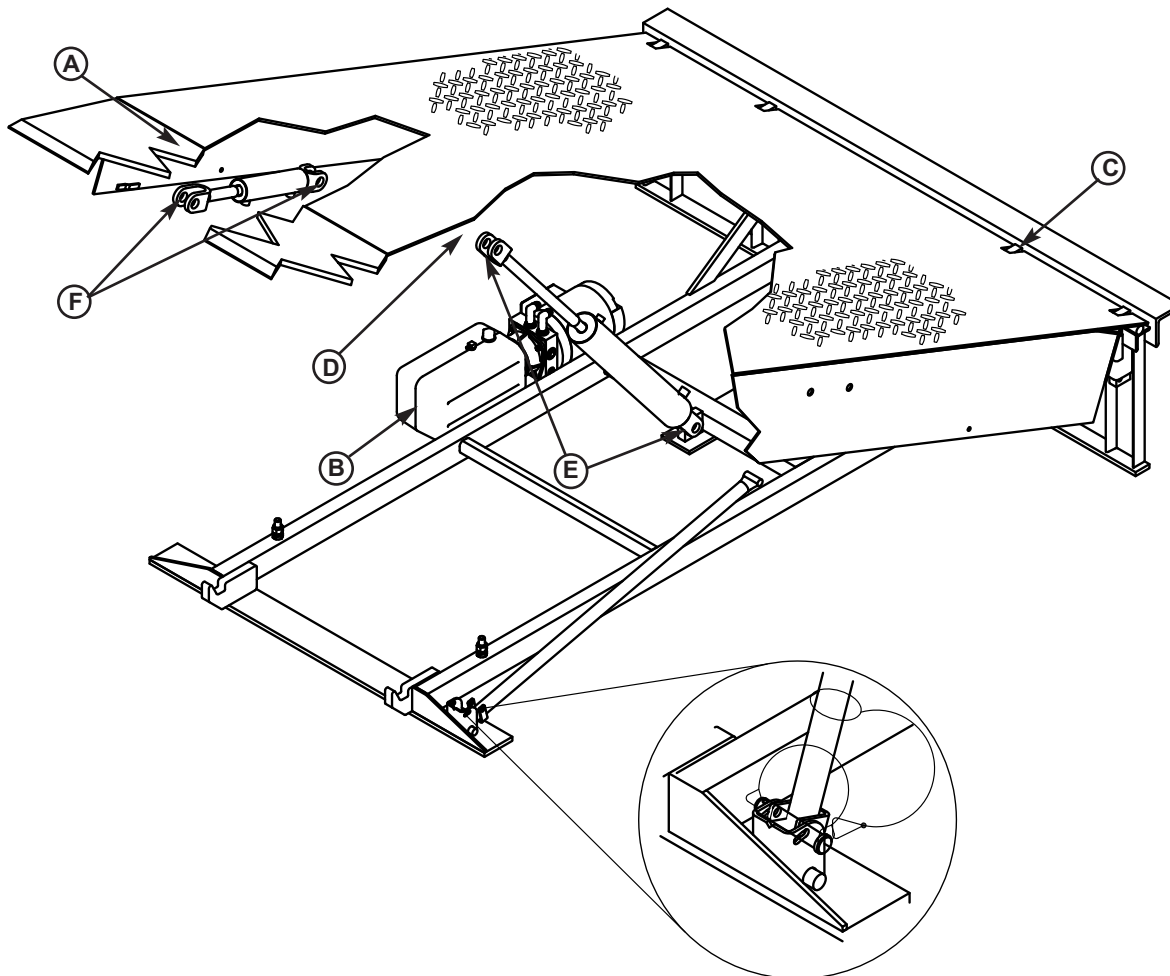

A—Lip Hinge Area C—Platform Hinge Area E—Platform Cylinder Pins
B—Power Unit and Reservoir D—Platform Cylinder Trunnion F—Lip Cylinder Pins

WARNING

Before performing any maintenance under the dock leveler, lock the electrical power source in OFF position and lock the maintenance prop in the service position using an approved locking device. (See Service Dock Leveler Safely in this section.)

Failure to follow these instructions may result in serious personal injury or death.

IMPORTANT

Use of fluids that do not have equivalent specifications to those in the following list will result in abnormal operation of the dock leveler and voiding of warranty.

To ensure normal operation of the dock leveler, use only aircraft hydraulic fluid designed to meet or exceed military specification MIL-L-5606. It is recommended that the following hydraulic fluids be used:

- ULTRA-VIS-HVI-15
- Flomite 530 ZF
- Aero Shell Fluid 4 or Fluid 41
- Mobile Aero HFA Mil-HS606A or Aero HF
- Texaco Aircraft Hydraulic Oil 15 or 5606
- Exxon Univis J13

These fluid brands can be mixed together. Mixing with fluids that do not meet or exceed MIL-L-5606 may damage the equipment and WILL void warranty. Use of hydraulic fluids with equivalent specifications to those listed here are acceptable.

Regular maintenance must be performed on a weekly and quarterly schedule.

Weekly Maintenance

- Operate the dock leveler through the complete operating cycle to maintain lubrication.

NOTE: To thoroughly inspect the platform hinge area, put the platform in the full below-dock position.

- Inspect the platform hinge and the lip hinge areas. The hinge areas must be kept free of dirt and debris. Build-up of foreign material in the hinge areas will cause abnormal operation.

Quarterly Maintenance

IMPORTANT

Failure to properly lubricate the dock leveler will cause abnormal operation of the leveler.

- Lubricate the following areas with light weight machine oil:
 - (A)—Lip hinge area unless equipped with grease fittings (apply oil to the top of the entire length of lip hinge when platform is at the full below-dock position and lip is folded)
 - (C)—Platform hinge area (apply oil to top of all platform hinges when platform is at the full below-dock position)
 - (E)—Platform cylinder-to-platform frame pin
 - (F)—Lip cylinder-to-platform frame pin
- Lubricate the following areas with white lithium grease:

NOTE: Apply grease to lip hinge grease fittings if equipped.

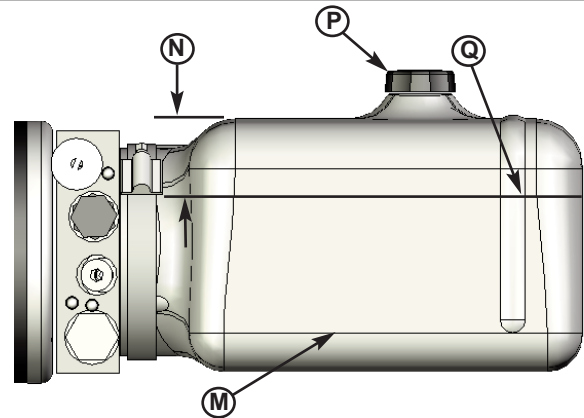

M -- Reservoir
N- 3 in. (76.5mm)
From Top of Reservoir

P - Breather Cap
Q - Fluid Level

IMPORTANT

A low fluid level or the use of hydraulic fluids not equivalent to the fluid types recommended, will cause abnormal operation of the leveler and WILL void warranty.

WARNING

Before performing any maintenance under the dock leveler, lock the electrical power source in OFF position and lock the maintenance prop in the service position using an approved locking device. (See Service Dock Leveler Safely in this section.)

Failure to follow these instructions may result in serious personal injury or death.

- Check reservoir fluid level (Q)(see note 3):
 1. Put the dock leveler platform at the full above-dock position and the lip extended.
 2. Turn OFF all electrical power to the leveler.
 3. Measure fluid level. The fluid level should be approximately 3 in. (76.5 mm) (N) from top of reservoir (M) with platform raised on the maintenance prop.
 4. Add hydraulic fluid if necessary. Use only recommended fluid. See page 22.
 5. Turn ON electrical power to the leveler.
 6. Return the platform to the cross-traffic position.

HYDRAULIC PUMP SCHEMATIC

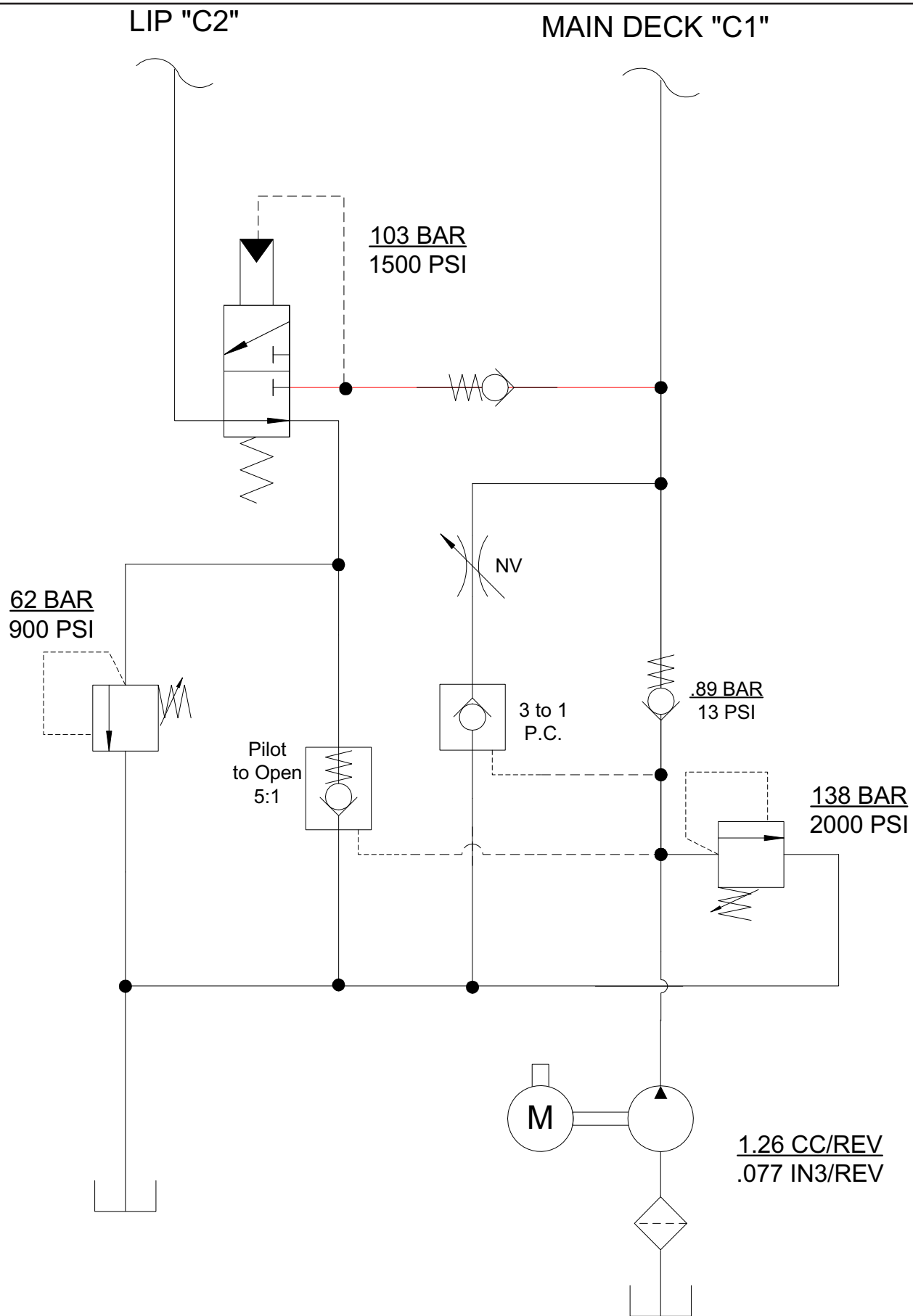

Adjust Main Pressure Relief

WARNING

When service under the dock leveler is required, always lock all electrical disconnects in the OFF position after raising the platform and engaging the maintenance prop. Failure to do this may result in serious personal injury or death.

WARNING

Always post safety warnings and barricade the work area at dock level and ground level to prevent unauthorized use of the dock leveler before maintenance is complete. Failure to do this may result in serious personal injury or death.

WARNING

Always stand clear of the dock leveler lip when working in front of the dock leveler.

The maintenance prop MUST be in the service position when working under the dock leveler. For maximum protection, use an OSHA approved locking device to lock the maintenance prop in the service position. Only the person servicing the equipment should have the key to unlock the maintenance prop.

Unless the dock leveler is equipped with a tethered remote, two people are required to engage the maintenance prop: one person to operate the unit, the other person to engage the maintenance prop.

Failure to follow these instructions may result in serious personal injury or death.

NOTE: *The main pressure relief may need to be increased if the platform does not rise or rises slowly and the system operates in pressure relief mode. See Troubleshooting section.*

The main pressure relief may need to be decreased if the pump motor loads down when platform reaches the full raised position. See Troubleshooting section.



- | | |
|---------------------------------------|---------------------------------|
| A—Shuttle Valve, Ramp Speed, Lowering | D—Reservoir |
| B—Lip Check Relief | E—Sequence Valve, Lip Extension |
| C—System P.O. Check | F—Main System Relief Valve |
| A/E MAIN ADJUSTMENT VALVES | G—P.O. Check Valve |

To adjust the main pressure relief:

1. Raise the platform fully and engage the maintenance prop in the service position.
2. Turn OFF all electrical power to the dock leveler. Attach safety lockout and tagout devices.
3. Loosen nut on valve (F)
4. Adjust hex adjusting screw (F) in small 1/4 turn increments as follows:
 - Turn clockwise to increase pressure relief.
 - Turn counterclockwise to decrease pressure relief.
5. Tighten the jam nut.
6. Turn ON electrical power to the dock leveler.
7. Disengage the maintenance prop.
8. Check leveler operation.
9. Repeat steps 1–8 as necessary.

Adjust Auto Return To Dock (ARTD)

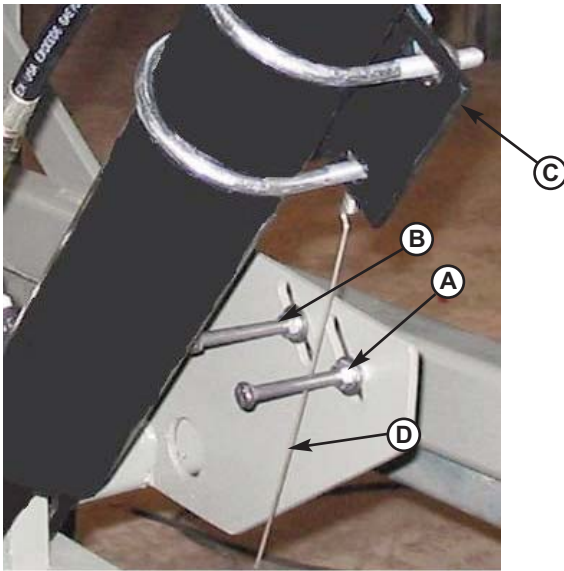

A—ARTD ACTIVATE C—ARTD LIMIT SWITCH
B—ARTD DE-ACTIVATE D—ARTD SWITCH ARM

HP/H levelers are equipped with the optional Auto Return To Dock (ARTD) if leveler not interlocked with a truck restraint.

The ARTD allows the platform to automatically return to the cross-traffic (stored) position after the truck departs.

Adjust the ARTD as Follows:

NOTE: Placement of (A, B and C) are typical factory settings. ARTD is set to engage approximately one(1) in. before the front header hits the header stops.

1. Raise platform fully and engage the maintenance prop in the service position.
2. Turn OFF all electrical power to the dock leveler. Attach safety lockout and tagout devices. (Supplied by others)
3. Loosen nuts (A). Slide bolt up to engage ARTD higher below dock or slide down to engage ARTD lower below dock. Tighten nuts.
4. Turn power back on and run the unit through a full cycle and repeat if necessary.
5. Loosen nut (B) and slide bolt up to shut ARTD higher above dock or slide the bolt down to shut off the ARTD less above dock.

! WARNING

When service under the dock leveler is required, always lock all electrical disconnects in the OFF position after raising the platform and engaging the maintenance prop. Failure to do this may result in serious personal injury or death.

! WARNING

Always post safety warnings and barricade the work area at dock level and ground level to prevent unauthorized use of the dock leveler before maintenance is complete. Failure to do this may result in serious personal injury or death.

! WARNING

Always stand clear of the dock leveler lip when working in front of the dock leveler.

The maintenance prop **MUST** be in the service position when working under the dock leveler. For maximum protection, use an OSHA approved locking device to lock the maintenance prop in the service position. Only the person servicing the equipment should have the key to unlock the maintenance prop.

Unless the dock leveler is equipped with a tethered remote, two people are required to engage the maintenance prop: one person to operate the unit, the other person to engage the maintenance prop.

Failure to follow these instructions may result in serious personal injury or death.

NOTE: The unit must raise enough to allow the lip to fully retract to have the lip rest in to the lip keepers.

NOTE: The ARTD Switch arm (D) must be between both (A) and (B) to work properly.

ADJUSTMENTS

Full Below-Dock Position

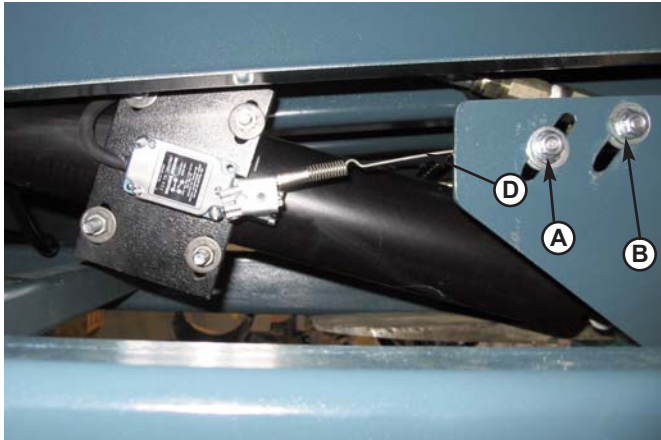

In the full below dock position the switch arm (D) will be activated by the front bolt (A) and trapped under the back bolt (B). The switch will activate approximately 1 inch before the front header is fully below dock.

As the platform starts to recycle the lip will pull in first and then the platform will start to raise. Once the platform is high enough to have the lip clear the lip keepers the back bolt (B) will de-activate the switch and turn off the pump and the platform will float down to rest in the lip keepers in the cross traffic position.

The Below Dock End Load Switch (E), controls the lip when end loading below dock. To activate turn the selector switch (F) to BELOW DOCK position.

This will DEACTIVATE the Auto Return to Dock feature.

Push and hold the RAISE button until the platform is fully open. The lip will extend until the switch opens up and stops the pump. The lip will be extended only 2 - 3 inches to stay with in the bumper spacing.

The platform will float to the full below dock position and the trailer and be loaded/unloaded.

When complete, turn the Selector Switch(F) back to the NORMAL position and the platform will start to Auto Recycle to the cross traffic position.

NOTE:

When servicing trailers that are lower than dock height it is recommended the BELOW DOCK selector switch (F) be in the BELOW DOCK mode AFTER the lip is in the bed of the trailer to prevent the Auto Return feature to activate inadvertently.

Below Dock End Load Switch

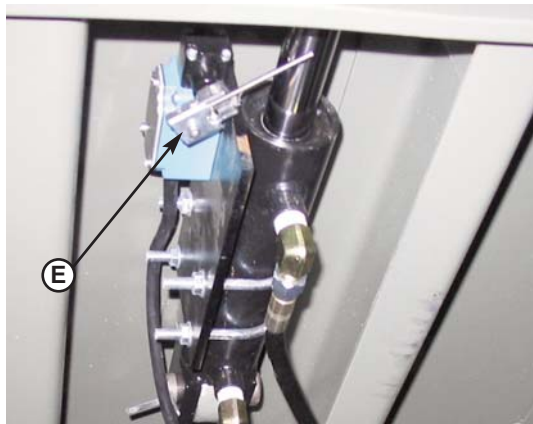

CAUTION

Whenever end loading or unloading with the platform in the below-dock position, make sure the ARTD switch is in the BELOW DOCK position. DO NOT turn the ARTD switch to the NORMAL position until end loading or unloading is finished.

ADJUSTMENTS

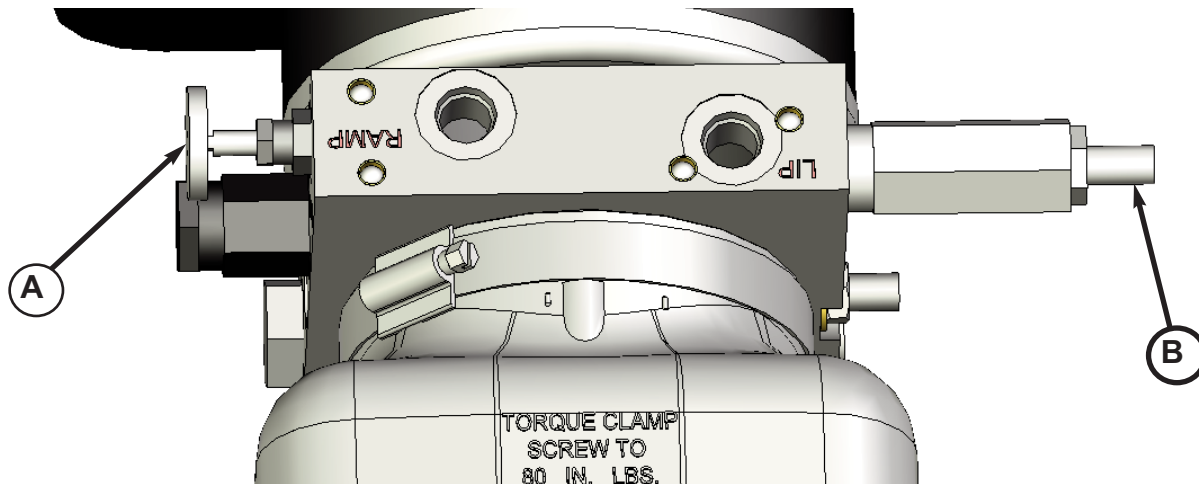

Down Speed Control Adjustment

If the dock leveler did not lower, it is possible that the speed control requires adjustment. The speed control adjusting screw (A) is a thumb screw located on the left side looking from the tank end of the unit, the top valve.

NOTE: If the platform lowers too fast, the platform will stop lowering and lock in "safety" mode.

Use 1/4 turn increments when adjusting the down speed control. Check platform lowering speed after each adjustment.

To adjust the speed control:

- a. Loosen the jam nut.
- b. To decrease the lowering speed, turn adjusting screw (A) clockwise.
- c. To increase the lowering speed, turn adjusting screw (A) counterclockwise.
- d. Tighten the jam nut.

NOTE: Extreme cold and/or incorrect fluid may also cause cylinder to lock. Adjust downspeed to decrease lowering speed.

Lip Extension Sequence Valve

Adjust the Sequence Valve if the lip does not extend all the way or if the lip starts to extend too soon.(B).

1. If the lip extends while the platform is raising, loosen the jam nut and turn the valve IN or Clockwise to delay the lip from extending. Tighten the jam nut and run the unit through a complete cycle.
2. If the lip does not extend fully, first check fluid level, if full, than loosen the jam nut and turn the valve OUT or Counter Clockwise to cause the lip to come out sooner. Tighten the jam nut and run the unit through a complete cycle.
3. Repeat as needed to achieve proper function of the unit. Call Technical Services if proper function can not be achieved.

ELECTRICAL OVERVIEW

Motor: 1HP, TENV, No.56 frame, 15 minute duty cycle

Return Switch: Maintain-contact type oil-tight enclosure, spring-arm actuation with adjustable tripper arrangement.

Lip Control Switch: Momentary contact, oil-tight enclosure. Actuated by lip cylinder.

Fluid Content: UNIVIS HVI-26

Replacement Hydraulic Fluid: We strongly recommend using the UNIVIS HVI-26, however you may replace the fluid with automatic transmission fluid type F or Dextron. Mixing any other fluid with UNIVIS HVI-26 will cause the fluid to break down. If in climates below zero we recommend replacing and refilling with UNIVIS HVI-26.



CAUTION: DO NOT USE ANY HYDRAULIC FLUID MENTIONED ABOVE.

Note: UNIVIS HVI-26 is designed for extremely cold climates and will break down if mixed with any other fluid; however you may mix with any hydraulic fluid for emergency use. **WE STRONGLY RECOMMEND DRAINING AND REFILLING WITH FRESH UNIVIS HVI-26 or EQUIVELENT AS SOON AS POSSIBLE.**

Tank Capacity

25K To 75K Levelers.....4 quarts

100K Levelers.....5 quarts

Motor Electrical Specifications

Motor Voltage	RPM	Hz	PHASE	AMP. DRAW MOTOR RUNNING	Elect. Serv. Amperage Req.
110/115/120	3450	60	1	14.4	30*
208	3450	60	1	7.1	20
220/230/240	3450	60	1	7.2	20
208	3450	60	3	3.6	10
220/240	3450	60	3	3.7	10
440-460-480	3450	60	3	1.8	10
575	3450	60	3	1.4	10

Guide to Wire Sizes

Length of Run	120/208 Volt	240Volt	220Volt	460Volt	575Volt
in Feet	1 Phase Wire Size	1 Phase Wire Size	3 Phase Wire Size	3 Phase Wire Size	3 Phase Wire Size
0-25	#10	#12	#12	#12	#12
25-45	#8	#12	#12	#12	#12
45-75	#6	#8	#10	#10	#10
75-120	#6	#8	#10	#10	#10
120-150	#4	#6	#8	#8	#8
150-220	NR	NR	NR	NR	NR



CAUTION: Sufficient voltage must reach the Leveler Control Panel to operate the 1 HP motor. Voltage drop caused by long wire runs or undersized wire increase the Amp draw and will cause the breaker to trip and/or more serious damage to occur. Therefore, it is important for installation to be done to meet all codes by a licensed electrician.

IMPORTANT NOTE: The values given are intended to only be a guide. Be sure to check all electrical codes before installation. This chart indicates the length of branch circuit having a 2% voltage drop at full load (start up) current in feet. Values are for THHN copper wire only.

ELECTRICAL 1 PHASE

NOTES

- A. DRAWING SHOWS SYSTEM AT REST WITH POWER OFF, DOCK LEVELER STORED, & OVERHEAD DOOR NOT FULLY RAISED.
- B. □ REPRESENTS A TERMINAL BLOCK.
- C. DOOR CONTACT (LINES 107 THRU 110) BY OTHERS. DOOR CONTACT MAY BE PROVIDED BY POWERAMP IF SPECIFIED. DOOR CONTACT TO PREVENT OPERATION OF LEVELER UNTIL DOOR FULLY RAISED. DOOR CONTACT TO BE OPEN WHEN DOOR NOT FULLY RAISED. DOOR CONTACT TO BE CLOSED WHEN DOOR FULLY RAISED. IF DOOR CONTACT IS USED REPLACE JUMPER AT TERMINAL BLOCKS 11 AND 13 WITH DOOR CONTACT WIRES.
- D. TERMINAL BLOCKS 14, 15, AND 16 ARE USED ONLY IF UNIT HAS AUTO RETURN. TERMINAL BLOCK 17 IS USED ONLY IF UNIT HAS LIP OUT AND/OR E-STOP.
- E. PB2 ONLY USED IF UNIT HAS LIP OUT.
WIRE 14 IS CONNECTED TO PB2-4 IF UNIT DOES NOT HAVE AUTO RETURN.
WIRE 15 IS CONNECTED TO PB2-4 IF UNIT HAS AUTO RETURN.
- F. PB3 ONLY USED IF UNIT HAS E-STOP.
WIRE 14 IS CONNECTED TO PB3-1 IF UNIT DOES NOT HAVE AUTO RETURN.
WIRE 15 IS CONNECTED TO PB3-1 IF UNIT HAS AUTO RETURN.
- G. WIRE 14 IS CONNECTED TO M1-A1 IF UNIT DOES NOT HAVE AUTO RETURN OR E-STOP.
WIRE 15 IS CONNECTED TO M1-A1 IF UNIT HAS AUTO RETURN BUT DOES NOT HAVE E-STOP.
WIRE 18 IS CONNECTED TO M1-A1 IF UNIT HAS E-STOP.
- H. WIRE COLORS NEAR COMPONENT REFER TO COLOR OF WIRE SUPPLIED BY THE COMPONENT MFR OR BY POWERAMP USING MULTICONDUCTOR CORD.
- I. NUMBERS NEAR COMPONENT REFER TO NUMBERS FOUND ON THE TERMINALS OF THE COMPONENT.

ONLY THE CONTROL ASSY IS A UL LISTED PANEL. ALL OTHER EQUIPMENT IS REMOTE FROM THE CONTROL ASSY AND IS NOT PART OF THE UL LISTED CONTROL ASSY.

LOAD DATA – EXTERNAL LOADS ALL LOADS 110–120 VAC	
LEGEND	AMP RATING
SOL A OPTIONAL	0.18 A @ 115 V

COMPONENT LOCATION TABLE. COMPONENT LOCATION INDICATED BY PHANTOM LINES (— — — — —)	
LEGEND	LOCATION
CA	CONTROL ASSY (UL LISTED PANEL)
DL	DOCK LEVELER
OD	OVERHEAD DOOR – BY OTHERS

ELECTRICAL 3 PHASE

NOTES	
A.	DRAWING SHOWS SYSTEM AT REST WITH POWER OFF, DOCK LEVELER STORED, & OVERHEAD DOOR NOT FULLY RAISED.
B.	□ REPRESENTS A TERMINAL BLOCK.
C.	DOOR CONTACT (LINES 109 THRU 112) BY OTHERS. DOOR CONTACT MAY BE PROVIDED BY POWERAMP IF SPECIFIED. DOOR CONTACT TO PREVENT OPERATION OF LEVELER UNTIL DOOR FULLY RAISED. DOOR CONTACT TO BE OPEN WHEN DOOR NOT FULLY RAISED. DOOR CONTACT TO BE CLOSED WHEN DOOR FULLY RAISED. IF DOOR CONTACT IS USED REPLACE JUMPER AT TERMINAL BLOCKS 11 AND 13 WITH DOOR CONTACT WIRES.
D.	TERMINAL BLOCKS 14, 15, AND 16 ARE USED ONLY IF UNIT HAS AUTO RETURN. TERMINAL BLOCK 17 IS USED ONLY IF UNIT HAS LIP OUT AND/OR E-STOP.
E.	PB2 ONLY USED IF UNIT HAS LIP OUT. WIRE 14 IS CONNECTED TO PB2-4 IF UNIT DOES NOT HAVE AUTO RETURN. WIRE 15 IS CONNECTED TO PB2-4 IF UNIT HAS AUTO RETURN.
F.	PB3 ONLY USED IF UNIT HAS E-STOP. WIRE 14 IS CONNECTED TO PB3-1 IF UNIT DOES NOT HAVE AUTO RETURN. WIRE 15 IS CONNECTED TO PB3-1 IF UNIT HAS AUTO RETURN.
G.	WIRE 14 IS CONNECTED TO M1-A1 IF UNIT DOES NOT HAVE AUTO RETURN OR E-STOP. WIRE 15 IS CONNECTED TO M1-A1 IF UNIT HAS AUTO RETURN BUT DOES NOT HAVE E-STOP. WIRE 18 IS CONNECTED TO M1-A1 IF UNIT HAS E-STOP.
H.	WIRE COLORS NEAR COMPONENT REFER TO COLOR OF WIRE SUPPLIED BY THE COMPONENT MFR OR BY POWERAMP USING MULTICONDUCTOR CORD.
I.	NUMBERS NEAR COMPONENT REFER TO NUMBERS FOUND ON THE TERMINALS OF THE COMPONENT.

ONLY THE CONTROL ASSY IS A UL LISTED PANEL. ALL OTHER EQUIPMENT IS REMOTE FROM THE CONTROL ASSY AND IS NOT PART OF THE UL LISTED CONTROL ASSY.

LOAD DATA – EXTERNAL LOADS ALL LOADS 110-120 VAC	
LEGEND	AMP RATING
SOL A OPTIONAL	0.18 A @ 115 V

COMPONENT LOCATION TABLE. COMPONENT LOCATION INDICATED BY PHANTOM LINES (-----)	
LEGEND	LOCATION
CA	CONTROL ASSY (UL LISTED PANEL)
DL	DOCK LEVELER
OD	OVERHEAD DOOR – BY OTHERS

TABLE 1 MOTOR NAMEPLATE DATA		
VOLTAGE	FLA	HP
230 V	3.6 A	1.25 HP
460 V	1.8 A	
208 V 3.8A		

TABLE 2	
VOLTAGE	FU1
230 V	1 A
460 V	0.5 A

CONTROL PANEL



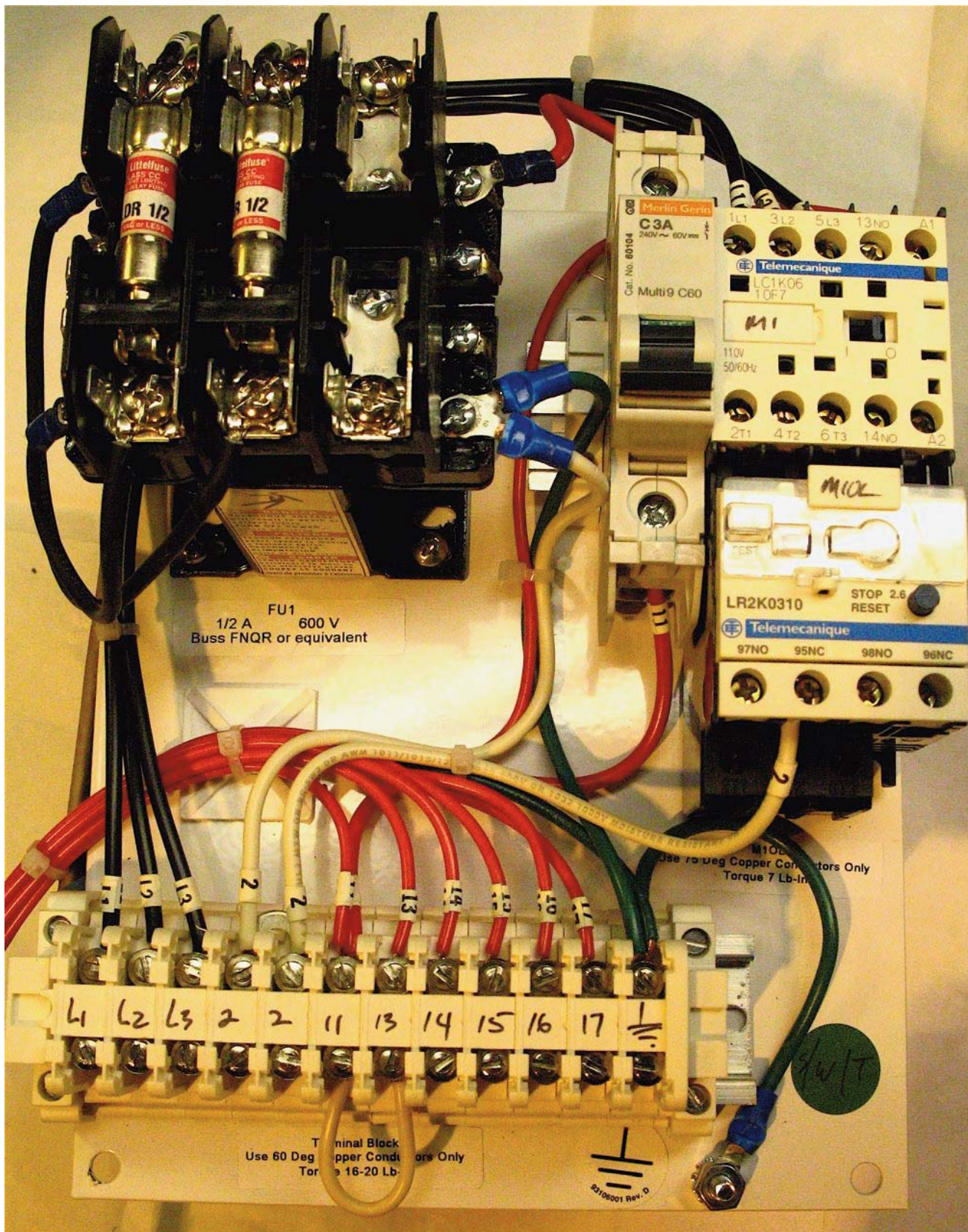

Typical 3PH panel lay out

* Provide dock leveler serial number, voltage, phase, and options when calling or faxing controller orders.

CONTROL BOX PARTS SINGLE PHASE

BILL OF MATERIAL			
LEGEND	QTY	PART NUMBER	DESCRIPTION
ENCL	1	SEE TABLE 1	ENCLOSURE
PNL	1	SEE TABLE 1	PANEL
TB1	5	1431-0219	TERMINAL BLOCK
	1	1431-0036	TERM BLOCK JUMPER
	1	1431-0220	TERM BLOCK END
	2	1431-0221	TERM BLOCK CLAMP
	5.0"	3051-0032	RAIL
TB2	3	1431-0219	TERMINAL BLOCK
	1	1431-0220	TERM BLOCK END
	2	1431-0221	TERM BLOCK CLAMP
	2.75"	3051-0032	RAIL
CB1	1	5101-0151	CIRCUIT BREAKER
M1	1	7141-0167	CONTACTOR
M10L	1	7141-0172	OVERLOAD RELAY [g]
PB1	1	0961-0285	PUSH BUTTON (IF NOT N4X FGLASS)
		0961-0334	PUSH BUTTON (IF N4X FGLASS)
KB1	1	0961-0293	MTG BASE W/ CONTACT BLOCK (IF NOT N4X FGLASS)
		0961-0341	MTG BASE W/ CONTACT BLOCK (IF N4X FGLASS)
-----	1	SEE TABLE 2	DECAL
-----	1	1751-0163	LABEL [b]
-----	2	1751-0363	LABEL [e]
-----	1	1751-0366	LABEL [e]

WIRE CHART			
WIRE			LOCATIONS
NO	COLOR	SIZE	
L1	BLACK	14 AWG	TB2, M1-L1
L1	RED	14 AWG	TB2, CB1
L2	BLACK	14 AWG	TB2, M1-L2
B	BLACK	14 AWG	M1-L3, M10L-T2
--	WHITE	14 AWG	TB2-N, TB1-2
2	WHITE	16-18 AWG	TB1, M10L-95
11	RED	14 AWG	TB1, CB1
---	YELLOW	14-16 AWG	TB1-11, TB1-13
13	RED	16-18 AWG	TB1, KB1-3
14	RED	16-18 AWG	KB1-4, M1-A1 (IF NO AUTO RETURN &/OR NO E-STOP)
18A	RED	16-18 AWG	M1-A2, M10L-96
---	GREEN	14 AWG	TB1, PNL GRD
---	GREEN	14 AWG	PNL GRD, ENCL DOOR [g]

[g] IF ENCLOSURE DOOR HAS A GROUNDING PROVISION.

OPTIONAL WIRING - AUTO RETURN

13	RED	16-18 AWG	ANY WIRE 13 TERMINAL, KB2-1
14	RED	16-18 AWG	TB1, KB2-1
15	RED	16-18 AWG	TB1, KB2-2, M1-A1 (IF NO E-STOP)
16	RED	16-18 AWG	TB1, KB2-2

OPTIONAL BILL OF MATERIAL - AUTO RETURN

TB1	3	1431-0219	TERMINAL BLOCK (14,15,16)
SS1	1	0961-0300	SELECTOR SWITCH (IF NOT N4X FGLASS)
		0961-0346	SELECTOR SWITCH (IF N4X FGLASS)
KB2	1	0961-0296	MTG BASE W/ CONTACT BLOCKS (IF NOT N4X FGLASS)
		0961-0344	MTG BASE W/ CONTACT BLOCKS (IF N4X FGLASS)

OPTIONAL WIRING - LIP OUT

11	RED	16-18 AWG	ANY WIRE 11 TERMINAL, KB3-3
13	RED	16-18 AWG	ANY WIRE 13 TERMINAL, KB3-3
14	RED	16-18 AWG	ANY WIRE 14 TERMINAL, KB3-4 (IF NO AUTO RETURN)
15	RED	16-18 AWG	ANY WIRE 15 TERMINAL, KB3-4 (IF AUTO RETURN)
17	RED	16-18 AWG	ANY WIRE 17 TERMINAL, KB3-4

OPTIONAL BILL OF MATERIAL - LIP OUT

TB1	1	1431-0219	TERMINAL BLOCK (17) [f]
PB2	1	0961-0402	PUSH BUTTON (IF NOT N4X FGLASS)
		0961-0404	PUSH BUTTON (IF N4X FGLASS)
KB3	1	0961-0295	MTG BASE W/ CONTACT BLOCKS (IF NOT N4X FGLASS)
		0961-0343	MTG BASE W/ CONTACT BLOCKS (IF N4X FGLASS)

OPTIONAL WIRING - E-STOP

11	RED	16-18 AWG	ANY WIRE 11 TERMINAL, KB4-3
14	RED	16-18 AWG	ANY WIRE 14 TERMINAL, KB4-1 (IF NO AUTO RETURN)
15	RED	16-18 AWG	ANY WIRE 15 TERMINAL, KB4-1 (IF AUTO RETURN)
17	RED	16-18 AWG	ANY WIRE 17 TERMINAL, KB4-4
18	RED	16-18 AWG	M1-A1, KB4-2

OPTIONAL BILL OF MATERIAL - E-STOP

TB1	1	1431-0219	TERMINAL BLOCK (17) [f]
PB3	1	0961-0292	PUSH BUTTON (IF NOT N4X FGLASS)
		0961-0340	PUSH BUTTON (IF N4X FGLASS)
KB4	1	0961-0297	MTG BASE W/ CONTACT BLOCKS (IF NOT N4X FGLASS)
		0961-0345	MTG BASE W/ CONTACT BLOCKS (IF N4X FGLASS)

[a] SET AT MOTOR FLA.

[b] COMPLETE LABEL AS SHOWN BELOW. AFFIX TO INSIDE OF DOOR.

DWG	9-MO-80B-B-E
208/120	VOLTS
1	PHASE
60	HZ
[c]	TOTAL FLA (MAXIMUM)
7.1	MOTOR FLA (LARGEST MOTOR)
1.25	MOTOR HP (LARGEST MOTOR)
ENCLOSURE TYPE [d]	
SHORT CIRCUIT CURRENT	
5	KA RMS SYMMETRICAL,
208	V MAXIMUM

[c] SEE TABLE 3.
[d] USE ENCLOSURE MFGR'S RATING.

TABLE 3		TOTAL FLA
LIP OUT AND/OR E-STOP		
NO		7.2 A
YES		7.3 A

TABLE 1							
NEMA 12		OPTIONAL NEMA 4		OPTIONAL NEMA 4X STAINLESS		OPTIONAL NEMA 4X FIBERGLASS	
ENCL	PNL	ENCL	PNL	ENCL	PNL	ENCL	PNL
2751-0092	2751-0047	2751-0072	2751-0047	2751-0141	2751-0127	2751-0132	2751-0047

TABLE 2						
FEATURES			MCGUIRE			
AUTO RETURN	LIP OUT	E-STOP	ENGLISH	FRENCH	SPANISH	NOVA
			1751-0559	1751-0567	1751-0575	1751-0675
X			1751-0560	1751-0568	1751-0576	1751-0676
	X		1751-0561	1751-0569	1751-0577	1751-0677
		X	1751-0562	1751-0570	1751-0578	1751-0678
X	X		1751-0563	1751-0571	1751-0579	1751-0679
X		X	1751-0564	1751-0572	1751-0580	1751-0680
	X	X	1751-0565	1751-0573	1751-0581	1751-0681
X	X	X	1751-0566	1751-0574	1751-0582	1751-0682

[e] AFFIX ADJACENT TO COMPONENT REFERRED TO.

[f] DO NOT DUPLICATE TERMINAL BLOCK 17. ONLY ONE TERMINAL BLOCK 17 IS REQUIRED IF UNIT HAS BOTH LIP OUT AND E-STOP.

CONTROL BOX PARTS SINGLE PHASE

DOOR – AS VIEWED FROM INSIDE WITH DOOR OPEN.
EXACT LOCATION OF COMPONENTS MAY BE DIFFERENT THAN WHAT IS SHOWN.

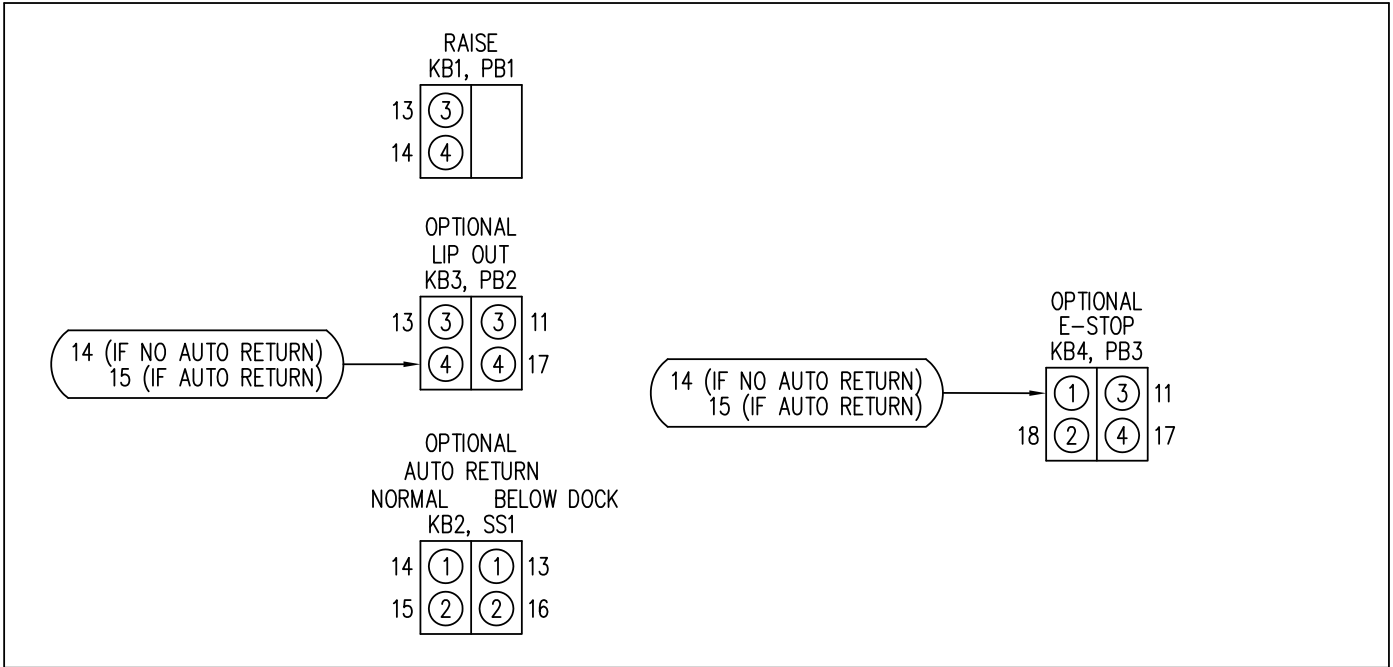

HINGE

PANEL – EXACT LOCATION OF COMPONENTS MAY BE DIFFERENT THAN WHAT IS SHOWN.

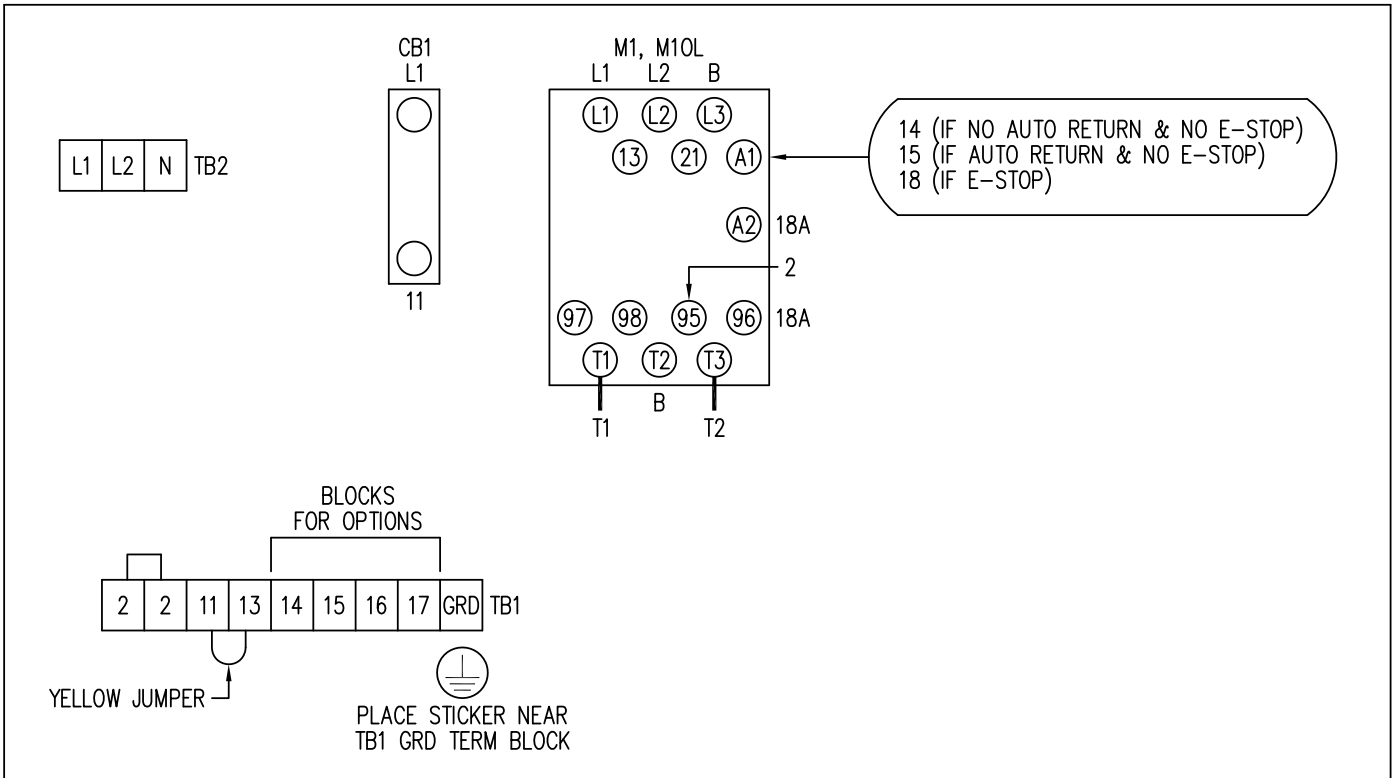

HINGE

ENCL, PNL

CONTROL BOX PARTS THREE PHASE

BILL OF MATERIAL			
LEGEND	QTY	PART NUMBER	DESCRIPTION
ENCL	1	SEE TABLE 1	ENCLOSURE
PNL	1	SEE TABLE 1	PANEL
TB1	8	1431-0219	TERMINAL BLOCK
	1	1431-0036	TERM BLOCK JUMPER
	1	1431-0220	TERM BLOCK END
	1	1431-0221	TERM BLOCK CLAMP
	6.0"	3051-0032	RAIL
T1	1	SEE TABLE 2	TRANSFORMER
FU1	2	SEE TABLE 2	FUSE
CB1	1	5101-0151	CIRCUIT BREAKER
M1	1	7141-0143	CONTACTOR
M1OL	1	7141-0148	OVERLOAD RELAY - 230 V [a]
		7141-0147	OVERLOAD RELAY - 460 V [a]
PB1	1	0961-0285	PUSH BUTTON (IF NOT N4X FGLASS)
		0961-0334	PUSH BUTTON (IF N4X FGLASS)
KB1	1	0961-0293	MTG BASE W/ CONTACT BLOCK (IF NOT N4X FGLASS)
		0961-0341	MTG BASE W/ CONTACT BLOCK (IF N4X FGLASS)
-----	1	SEE TABLE 3	DECAL
-----	1	1751-0163	LABEL [b]
-----	1	1751-0363	LABEL [g]
-----	1	1751-0367	LABEL [g]
-----	1	1751-0365	LABEL [g]

WIRE CHART			
WIRE			LOCATIONS
NO	COLOR	SIZE	
REMOVE RED WIRE PROVIDED BY TRANSFORMER MFR			
L1	BLACK	14 AWG	TB1, M1-L1, T1-H1
L2	BLACK	14 AWG	TB1, M1-L2, T1-HF
L3	BLACK	14 AWG	TB1, M1-L3
2	WHITE	16-18 AWG	TB1, M1OL-95, X2
11	RED	14 AWG	TB1, CB1
---	YELLOW	14-16 AWG	TB1-11, TB1-13
13	RED	16-18 AWG	TB1, KB1-3
14	RED	16-18 AWG	KB1-4, M1-A1 (IF NO AUTO RETURN &/OR NO E-STOP)
---	GREEN	14 AWG	TB1, T1-X2
---	GREEN	14 AWG	TB1, PNL GRD
---	GREEN	14 AWG	PNL GRD, ENCL DOOR [i]

[i] IF ENCLOSURE DOOR HAS A GROUNDING PROVISION.

OPTIONAL WIRING - AUTO RETURN			
13	RED	16-18 AWG	ANY WIRE 13 TERMINAL, KB2-1
14	RED	16-18 AWG	TB1, KB2-1
15	RED	16-18 AWG	TB1, KB2-2, M1-A1 (IF NO E-STOP)
16	RED	16-18 AWG	TB1, KB2-2

OPTIONAL BILL OF MATERIAL - AUTO RETURN			
TB1	3	1431-0219	TERMINAL BLOCK (14,15,16)
SS1	1	0961-0300	SELECTOR SWITCH (IF NOT N4X FGLASS)
		0961-0346	SELECTOR SWITCH (IF N4X FGLASS)
KB2	1	0961-0296	MTG BASE W/ CONTACT BLOCKS (IF NOT N4X FGLASS)
		0961-0344	MTG BASE W/ CONTACT BLOCKS (IF N4X FGLASS)

OPTIONAL WIRING - LIP OUT			
11	RED	16-18 AWG	ANY WIRE 11 TERMINAL, KB3-3
13	RED	16-18 AWG	ANY WIRE 13 TERMINAL, KB3-3
14	RED	16-18 AWG	ANY WIRE 14 TERMINAL, KB3-4 (IF NO AUTO RETURN)
15	RED	16-18 AWG	ANY WIRE 15 TERMINAL, KB3-4 (IF AUTO RETURN)
17	RED	16-18 AWG	ANY WIRE 17 TERMINAL, KB3-4

OPTIONAL BILL OF MATERIAL - LIP OUT			
TB1	1	1431-0219	TERMINAL BLOCK (17) [h]
PB2	1	0961-0402	PUSH BUTTON (IF NOT N4X FGLASS)
		0961-0404	PUSH BUTTON (IF N4X FGLASS)
KB3	1	0961-0295	MTG BASE W/ CONTACT BLOCKS (IF NOT N4X FGLASS)
		0961-0343	MTG BASE W/ CONTACT BLOCKS (IF N4X FGLASS)

OPTIONAL WIRING - E-STOP			
11	RED	16-18 AWG	ANY WIRE 11 TERMINAL, KB4-3
14	RED	16-18 AWG	ANY WIRE 14 TERMINAL, KB4-1 (IF NO AUTO RETURN)
15	RED	16-18 AWG	ANY WIRE 15 TERMINAL, KB4-1 (IF AUTO RETURN)
17	RED	16-18 AWG	ANY WIRE 17 TERMINAL, KB4-4
18	RED	16-18 AWG	M1-A1, KB4-2

OPTIONAL BILL OF MATERIAL - E-STOP			
TB1	1	1431-0219	TERMINAL BLOCK (17) [h]
PB3	1	0961-0292	PUSH BUTTON (IF NOT N4X FGLASS)
		0961-0340	PUSH BUTTON (IF N4X FGLASS)
KB4	1	0961-0297	MTG BASE W/ CONTACT BLOCKS (IF NOT N4X FGLASS)
		0961-0345	MTG BASE W/ CONTACT BLOCKS (IF N4X FGLASS)

TABLE 1							
NEMA 12		OPTIONAL NEMA 4		OPTIONAL NEMA 4X STAINLESS		OPTIONAL NEMA 4X FIBERGLASS	
ENCL	PNL	ENCL	PNL	ENCL	PNL	ENCL	PNL
2751-0092	2751-0047	2751-0072	2751-0047	2751-0141	2751-0127	2751-0132	2751-0047

[a] SET AT MOTOR FLA.

[b] COMPLETE LABEL AS SHOWN BELOW. AFFIX TO INSIDE OF DOOR.

DWG	9-MO-80B-L-E
[c]	VOLTS
3	PHASE
60	HZ
[d]	TOTAL FLA (MAXIMUM)
[d]	MOTOR FLA (LARGEST MOTOR)
1.25	MOTOR HP (LARGEST MOTOR)
	ENCLOSURE TYPE [e]
SHORT CIRCUIT CURRENT	
5	KA RMS SYMMETRICAL,
[f]	V MAXIMUM

[c] USE 230 OR 460.

[d] SEE TABLE 4.

[e] USE ENCLOSURE MFR'S RATING.

[f] USE 240 OR 480.

VOLTAGE	TABLE 2		AMPS
	T1	FU1	
230 V	1841-0066	5101-0038	1 A
460 V	1841-0066	5101-0072	0.5 A

VOLTAGE	TABLE 4	
	TOTAL FLA	MOTOR FLA
230 V	3.8 A	3.6 A
460 V	1.9 A	1.8 A

TABLE 3						
FEATURES			MCGUIRE		NOVA	
AUTO RETURN	LIP OUT	E-STOP	ENGLISH	FRENCH	SPANISH	ENGLISH
			1751-0559	1751-0567	1751-0575	1751-0675
X			1751-0560	1751-0568	1751-0576	1751-0676
	X		1751-0561	1751-0569	1751-0577	1751-0677
		X	1751-0562	1751-0570	1751-0578	1751-0678
X	X		1751-0563	1751-0571	1751-0579	1751-0679
X		X	1751-0564	1751-0572	1751-0580	1751-0680
	X	X	1751-0565	1751-0573	1751-0581	1751-0681
X	X	X	1751-0566	1751-0574	1751-0582	1751-0682

[g] AFFIX ADJACENT TO COMPONENT REFERRED TO.

[h] DO NOT DUPLICATE TERMINAL BLOCK 17. ONLY ONE TERMINAL BLOCK 17 IS REQUIRED IF UNIT HAS BOTH LIP OUT AND E-STOP.

CONTROL BOX PARTS THREE PHASE

DOOR – AS VIEWED FROM INSIDE WITH DOOR OPEN.
EXACT LOCATION OF COMPONENTS MAY BE DIFFERENT THAN WHAT IS SHOWN.

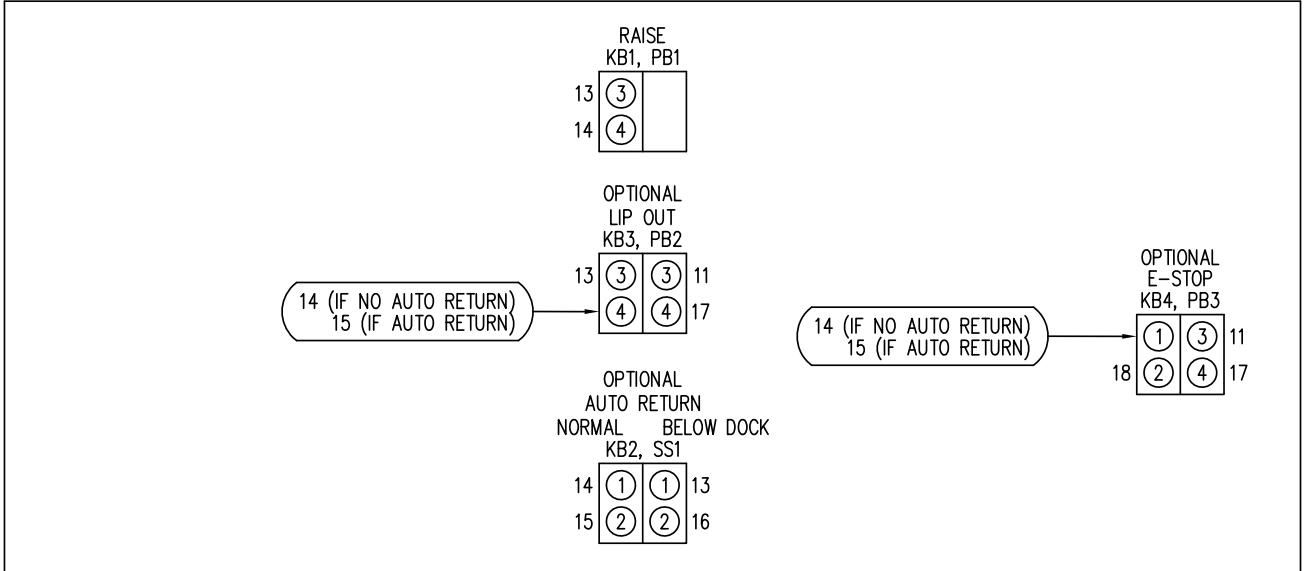

PANEL – EXACT LOCATION OF COMPONENTS MAY BE DIFFERENT THAN WHAT IS SHOWN.

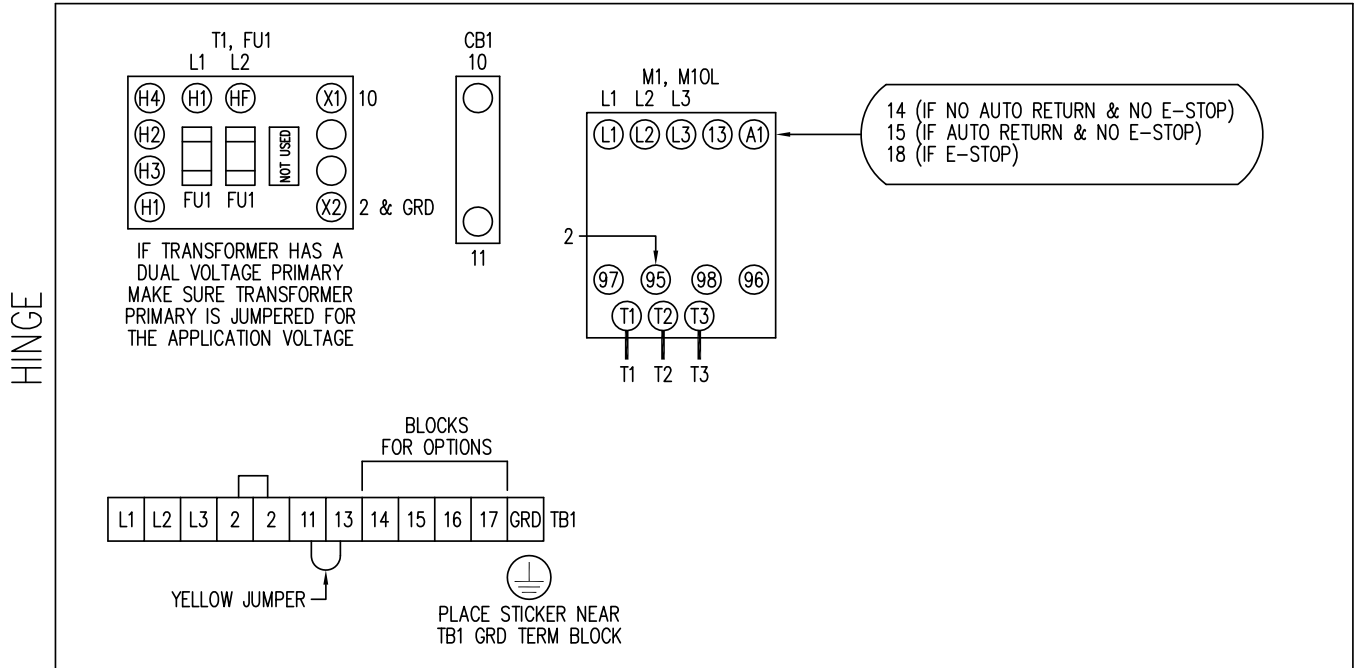

ENCL, PNL

Troubleshooting

WARNING

When service under the dock leveler is required, always lock all electrical disconnects in the OFF position after raising the platform and engaging the maintenance prop. Failure to do this may result in serious personal injury or death.

WARNING

Always post safety warnings and barricade the work area at dock level and ground level to prevent unauthorized use of the dock leveler before maintenance is complete. Failure to do this may result in serious personal injury or death.

WARNING

Always stand clear of the dock leveler lip when working in front of the dock leveler.

The maintenance prop **MUST** be in the service position when working under the dock leveler. For maximum protection, use an OSHA approved locking device to lock the maintenance prop in the service position. Only the person servicing the equipment should have the key to unlock the maintenance prop.

Unless the dock leveler is equipped with a tethered remote, two people are required to engage the maintenance prop: one person to operate the unit, the other person to engage the maintenance prop.

Failure to follow these instructions may result in serious personal injury or death.

Before performing the detailed troubleshooting procedures, check the following items first:

- Check all fuses inside the control panel(s). Replace any blown fuse(s) with a fuse of equal specification. Make sure to pull the fuses out of the circuit to test.
- Make sure the correct voltages are present at the proper locations inside the control panel(s).

Symptom	Possible Cause	Solution
Platform does not rise. Motor does not energize.	Motor overload device tripped or fuse blown.	Reset overload relay (three-phase) or replace fuse(s) (single-phase). Determine cause of overload. <i>NOTE: When replacing fuse(s), the new fuse must have the same specification as the old fuse.</i>
	Motor starter (three-phase) or motor relay (single-phase) not energizing.	Check voltage at starter or relay coil. <ul style="list-style-type: none"> • If voltage is present and starter or relay does not energize, replace starter or relay. • If voltage is not present, check all components in series with the starter or relay coil.

TROUBLESHOOTING

Symptom	Possible Cause	Solution
Three-phase units only: Platform does not rise. Motor hums, but does not run.	No voltage is present on one line.	Check for blown fuses at branch circuit disconnect. Replace fuse. Determine cause of blown fuse.
	<i>NOTE: A motor that is missing voltage on one line is said to be single-phased.</i>	Check motor starter as follows: 1. Disconnect wires at load side of starter. 2. Energize the starter. 3. Measure line-to-line voltage at line side of starter. 4. Measure line-to-line voltage at load side of starter. 5. Line-side and load-side voltages should be approximately the same. Replace starter if voltage values are considerably different from one another.
		Check all wiring to motor for high resistance or no connection.
Three-phase units only: Platform does not rise. Motor runs in reverse	Phase reversed.	Reverse any two legs at the branch circuit disconnect.
Single-phase units only: Platform does not rise. Motor energizes, but does not run.	Line voltage too low.	Check wiring to motor for high resistance. Check for loose or corroded connections. Check if gauge of wires to motor are of correct size and specification for load requirement. Replace if necessary.
	Defective motor centrifugal switch.	Replace motor.
	Defective motor capacitor.	Replace motor.
Dock leveler equipped with ARTD: Platform does not automatically return to the cross-traffic position or operates abnormally.	The auto return limit switch not activating correctly.	Adjust the bolts as needed. See Adjust Auto Return To Dock (ARTD) in the Adjustment section.
	Defective limit switch.	Replace switch.
	Broken wire. Loose or corroded wire connections.	Repair or replace wires and connections as necessary.

TROUBLESHOOTING

Symptom	Possible Cause	Solution
Platform does not rise. Pump operates in pressure relief mode.	Heavy object(s) on platform.	Remove object(s) from platform. NOTE: <i>For safety reasons, the dock leveler is designed to lift only the platform's own weight. The motor will continue to run which will result in melting the reservoir.</i>
	Dock leveler binds.	Check for visible obstructions that could cause binding. Remove obstructions. If no obstructions found, call Systems, Inc. Technical Services. See inside back cover for phone number and address.
	Pressure relief set too low.	Increase pressure relief. See Adjust Main Pressure Relief in the Adjustment section. NOTE: <i>The pressure relief valve must not be set at a level that causes the motor operating current to exceed the full load amp value* at any time, including when operating in pressure relief.</i> <small>*The full load amp value can be found on the inside cover of the control panel.</small>
Platform rises slowly.	Low hydraulic fluid.	Add fluid as needed. See Periodic Maintenance in the Maintenance section.
	Contaminated hydraulic system.	Clean and inspect valves. Flush contaminated oil from hydraulic system. Fill system with new oil. See Periodic Maintenance in the Maintenance section.
	Damaged or restricted hydraulic hose(s).	Replace damaged hose(s). Remove restriction.
	Pressure relief set too low.	Increase pressure relief. See Adjust Main Pressure Relief in the Adjustment section. NOTE: <i>The pressure relief valve must not be set at a level that causes the motor operating current to exceed the full load amp value* at any time, including when operating in pressure relief.</i> <small>*The full load amp value can be found on the inside cover of the control panel.</small>
Pump motor loads down when platform reaches the full raised position.	Pressure relief set too high.	Decrease pressure relief. See Adjust Main Pressure Relief in the Adjustment section. NOTE: <i>The pressure relief valve must not be set at a level that causes the motor operating current to exceed the full load amp value* at any time, including when operating in pressure relief.</i> <small>*The full load amp value can be found on the inside cover of the control panel.</small>

TROUBLESHOOTING

Symptom	Possible Cause	Solution
Platform does not rise to full height.	Low hydraulic fluid.	Add fluid as needed. See Periodic Maintenance in the Maintenance section.
Platform DOES rise to full height, but lip DOES NOT extend or extend fully.	Low hydraulic fluid.	Add fluid as needed. See Periodic Maintenance in the Maintenance section.
	The BELOW DOCK switch is in the BELOW DOCK position	Turn the switch to the NORMAL position.
Lip does not extend.	Sequence valve out of adjustment	Adjust the sequence valve out(countner clock wise) to get the lip to swing out sooner.
Lip extends almost immediately when the RAISE button is pushed.	Sequence valve out of adjustment	Adjust the sequence value in(clock wise) to keep the lip from swinging out too soon.
Platform locks into "safety" as platform lowers. Lip drops to vertical position.	Platform lowering speed is too fast.	Adjust platform down speed control. See Down Speed Control in the Adjustment section. <i>NOTE: Extreme cold weather OR incorrect fluid may cause platform to lock. Adjustment is same.</i>

PARTS

Frame - Platform - Lip

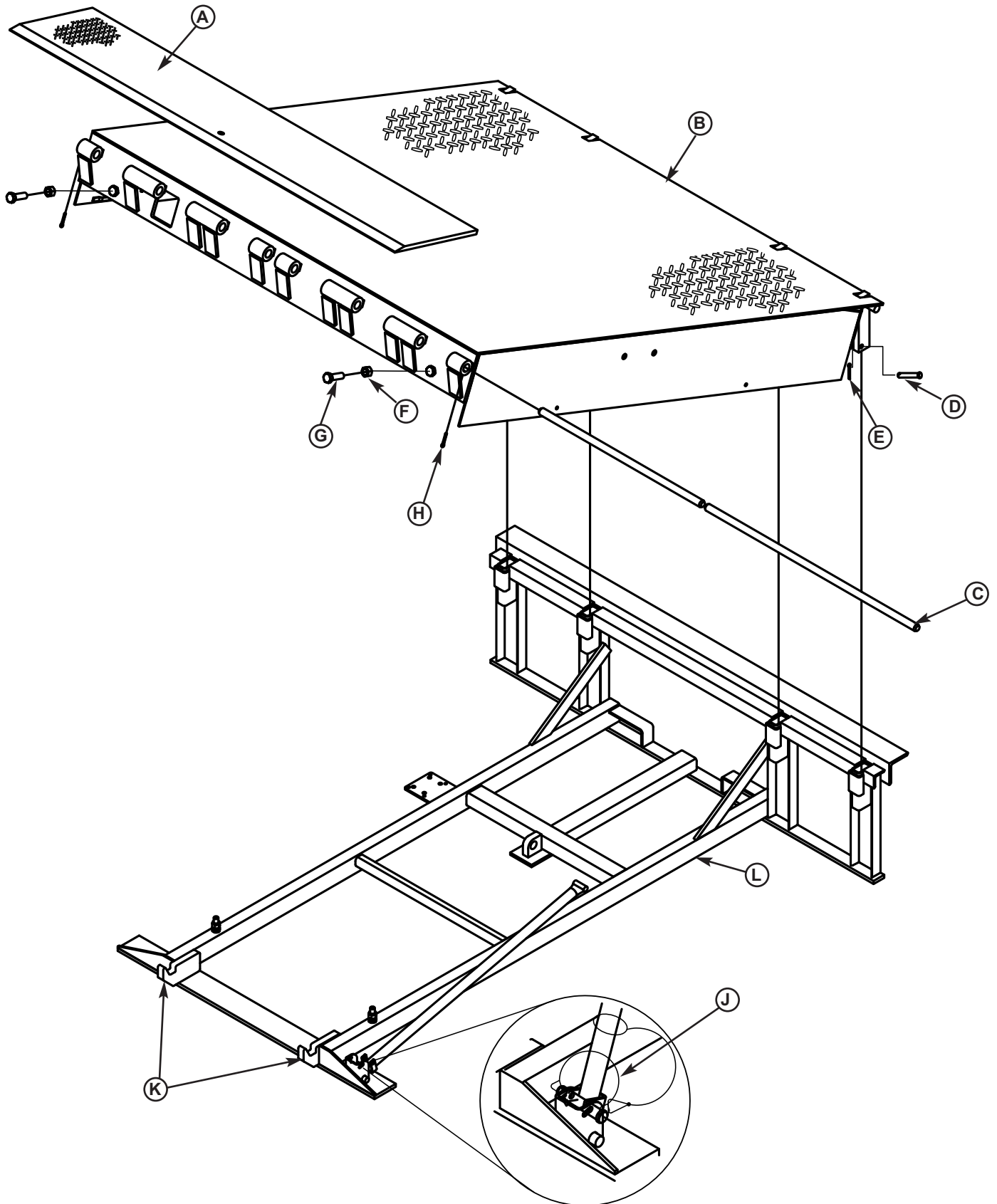

Lip and Platform

ITEM	QTY			LIPS						
A		6.0 FOOT	<u>25K</u>	<u>30K</u>	<u>35K</u>	<u>40/45K</u>	<u>55K</u>	<u>75K</u>	<u>100K</u>	
	1	16	0595-5045	0595-5054	0595-5063	0595-5072	0595-5081	0595-5090	0595-5099	
	1	18	0595-5046	0595-5055	0595-5064	0595-5073	0595-5082	0595-5091	0595-5100	
	1	20	0595-5047	0595-5056	0595-5065	0595-5074	0595-5083	0595-5092	0595-5101	
		6.5 FOOT								
	1	16	0595-5048	0595-5057	0595-5066	0595-5075	0595-5084	0595-5093	0595-5102	
	1	18	0595-5049	0595-5058	0595-5067	0595-5076	0595-5085	0595-5094	0595-5103	
	1	20	0595-5050	0595-5059	0595-5068	0595-5077	0595-5086	0595-5095	0595-5104	
		7.0 FOOT								
	1	16	0595-5051	0595-5060	0595-5069	0595-5078	0595-5087	0595-5096	0595-5105	
	1	18	0595-5052	0595-5061	0595-5070	0595-5079	0595-5088	0595-5097	0595-5106	
	1	20	0595-5053	0595-5062	0595-5071	0595-5080	0595-5089	0595-5098	0595-5107	
					PLATFORMS					
ITEM	QTY			6 FOOT				8 FOOT		
B			6.0 FOOT	6.5 FOOT	7.0 FOOT		6.0 FOOT	6.5 FOOT	7.0 FOOT	
	1	<u>25K</u>	9515-5054	9515-5058	9515-5062	<u>25K</u>	9515-5066	9515-5070	9515-5074	
	1	<u>30K</u>	9515-5055	9515-5059	9515-5063	<u>30K</u>	9515-5067	9515-5071	9515-5075	
	1	<u>35K</u>	9515-5056	9515-5060	9515-5064	<u>35K</u>	9515-5068	9515-5072	9515-5076	
	1	<u>40K</u>	9515-5057	9515-5061	9515-5065	<u>40K</u>	9515-5069	9515-5073	9515-5077	
	1	<u>45K</u>	9515-5102	9515-5106	9515-5110	<u>45K</u>	9515-5114	9515-5118	9515-5122	
	1	<u>55K</u>	9515-5103	9515-5107	9515-5111	<u>55K</u>	9515-5115	9515-5119	9515-5123	
	1	<u>75K</u>	9515-5104	9515-5108	9515-5112	<u>75K</u>	9515-5116	9515-5120	9515-5124	
	1	<u>100K</u>	9515-5105	9515-5109	9515-5113	<u>100K</u>	9515-5117	9515-5121	9515-5125	
ITEM	QTY			10 FOOT				12 FOOT		
B			6.0 FOOT	6.5 FOOT	7.0 FOOT		6.0 FOOT	6.5 FOOT	7.0 FOOT	
	1	<u>25K</u>	9515-5078	9515-5082	9515-5086	<u>25K</u>	9515-5090	9515-5094	9515-5098	
	1	<u>30K</u>	9515-5079	9515-5083	9515-5087	<u>30K</u>	9515-5091	9515-5095	9515-5099	
	1	<u>35K</u>	9515-5080	9515-5084	9515-5088	<u>35K</u>	9515-5092	9515-5096	9515-5100	
	1	<u>40K</u>	9515-5081	9515-5085	9515-5089	<u>40K</u>	9515-5093	9515-5097	9515-5101	
	1	<u>45K</u>	9515-5126	9515-5130	9515-5134	<u>45K</u>	9515-5138	9515-5142	9515-5146	
	1	<u>55K</u>	9515-5127	9515-5131	9515-5135	<u>55K</u>	9515-5139	9515-5143	9515-5147	
	1	<u>75K</u>	9515-5128	9515-5132	9515-5136	<u>75K</u>	9515-5140	9515-5144	9515-5148	
	1	<u>100K</u>	9515-5129	9515-5133	9515-5137	<u>100K</u>	9515-5141	9515-5145	9515-5149	

¹ Provide dock leveler serial number, platform size, and lip size when calling or faxing orders.

* For left/right orientation of dock leveler, see inside back cover of this manual.

PARTS

C		LIP SHAFTS	25K-100K
	2	6.0 FOOT	DPLA-2101
	2	6.5 FOOT	DPLA-2102
	2	7.0 FOOT	DPLA-2103
D	4	DOTH-2355	PIN, CLEVIS
E	4	DOTH-2373	PIN, COTTER
F	2	DOTH-2160	NUT, HEX 5/8-11 UNC
G	2	DOTH-2074	BOLT, 5/8-11 UNC X 2.00 INCH
H	2	DOTH-2382	PIN, COTTER 1/4 X 2
J	1	9201-0006	PROP PIN AND CLIP
K	2	8432-1129	KEEPER LIP 16
	2	8432-1130	KEEPER LIP 18
	2	8432-1131	KEEPER LIP 20

K	2	8432-1132	KEEPER LIP 16 24 pit
	2	8432-1133	KEEPER LIP 18 24 pit
	2	8432-1134	KEEPER LIP 20 24 pit

		BASE FRAMES							
ITEM	QTY	6 FOOT		8 FOOT		10 FOOT		12 FOOT	
							24 INCH PIT		24 INCH PIT
L		6.0 FOOT	25K/55K	6.0 FOOT	25K/55K	6.0 FOOT	25K/55K	6.0 FOOT	25K/55K
	1	16	8435-5027	16	8435-5030	16	8435-5033	16	8435-5036
	1	18	8435-5028	18	8435-5031	18	8435-5034	18	8435-5037
	1	20	8435-5029	20	8435-5032	20	8435-5035	20	8435-5038
		6.5 FOOT		6.5 FOOT		6.5 FOOT		6.5 FOOT	
	1	16	8435-5039	16	8435-5042	16	8435-5045	16	8435-5048
	1	18	8435-5040	18	8435-5043	18	8435-5046	18	8435-5049
	1	20	8435-5041	20	8435-5044	20	8435-5047	20	8435-5050
		7.0 FOOT		7.0 FOOT		7.0 FOOT		7.0 FOOT	
	1	16	8435-5051	16	8435-5054	16	8435-5057	16	8435-5060
	1	18	8435-5052	18	8435-5055	18	8435-5058	18	8435-5061
	1	20	8435-5053	20	8435-5056	20	8435-5059	20	8435-5062
		6.0 FOOT	75K(24 pit)	6.0 FOOT	75K(24 pit)	6.0 FOOT	75K(24 pit)	6.0 FOOT	75K(24 pit)
	1	16	8435-5063	16	8435-5066	16	8435-5069	16	8435-5072
	1	18	8435-5064	18	8435-5067	18	8435-5070	18	8435-5073
	1	20	8435-5065	20	8435-5068	20	8435-5071	20	8435-5074
		6.5 FOOT		6.5 FOOT		6.5 FOOT		6.5 FOOT	
	1	16	8435-5075	16	8435-5078	16	8435-5081	16	8435-5084
	1	18	8435-5076	18	8435-5079	18	8435-5082	18	8435-5085
	1	20	8435-5077	20	8435-5080	20	8435-5083	20	8435-5086
		7.0 FOOT		7.0 FOOT		7.0 FOOT		7.0 FOOT	
	1	16	8435-5087	16	8435-5090	16	8435-5093	16	8435-5096
	1	18	8435-5088	18	8435-5091	18	8435-5094	18	8435-5097
	1	20	8435-5089	20	8435-5092	20	8435-5095	20	8435-5098
		6.0 FOOT	100K(24 pit)	6.0 FOOT	100K(24 pit)	6.0 FOOT	100K(24 pit)	6.0 FOOT	100K(24 pit)
	1	16	8435-5099	16	8435-5102	16	8435-5105	16	8435-5108
	1	18	8435-5100	18	8435-5103	18	8435-5106	18	8435-5109
	1	20	8435-5101	20	8435-5104	20	8435-5107	20	8435-5110
		6.5 FOOT		6.5 FOOT		6.5 FOOT		6.5 FOOT	
	1	16	8435-5111	16	8435-5114	16	8435-5117	16	8435-5120
	1	18	8435-5112	18	8435-5115	18	8435-5118	18	8435-5121
	1	20	8435-5113	20	8435-5116	20	8435-5119	20	8435-5122
		7.0 FOOT		7.0 FOOT		7.0 FOOT		7.0 FOOT	
	1	16	8435-5123	16	8435-5126	16	8435-5129	16	8435-5132
	1	18	8435-5124	18	8435-5127	18	8435-5130	18	8435-5133
	1	20	8435-5125	20	8435-5128	20	8435-5131	20	8435-5134

This page intentionally left blank

PARTS

Hydraulic Components

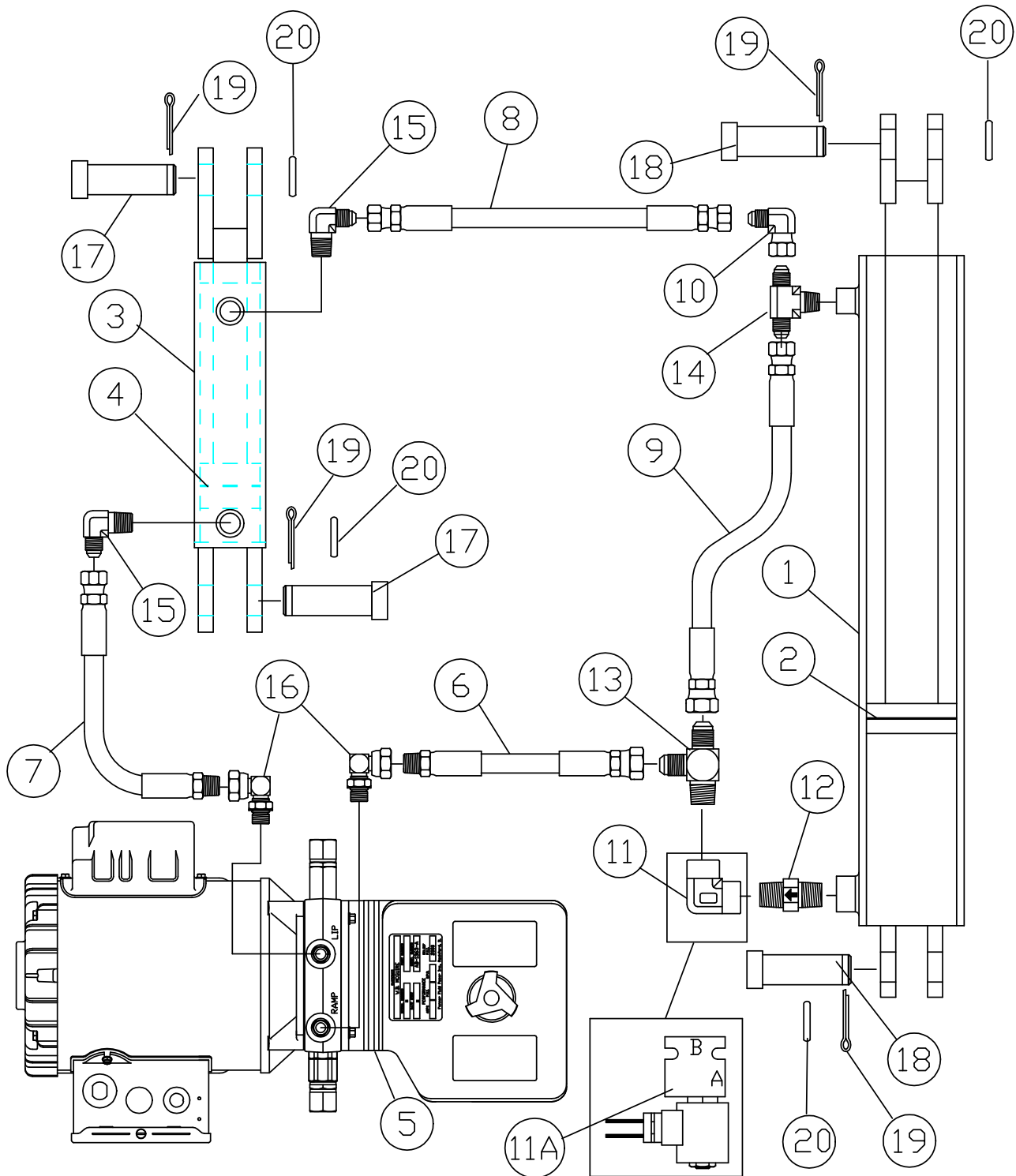

Hydraulic Components

1	0525-0106	MAIN CYLINDER 3 x 18"	1
	0525-0107	MAIN CYLINDER 4 x 18" (75K and 100K)	1
2	111-275	SEAL KIT MAIN CYL.3 x 18"	1
	111-274	SEAL KIT MAIN CYL.4 x 18"	1
3	0525-0108	LIP CYLINDER	1
4	111-094	SEAL KIT LIP CYLINDER	1
5	111-374	MOTOR PUMP ASSY. 1PH	1
	111-375	MOTOR PUMP ASSY. 3PH	1
6	111-077	HOSE ASSEMBLE MAIN	1
7	111-075	HOSE ASSEMBLY LIP 6 FOOTLONG	1
7	111-078	HOSE ASSEMBLY LIP 8 FOOT LONG	1
7	111-078	HOSE ASSEMBLY LIP 10 FOOT LONG	1
8	111-074	HOSE ASSEMBLY MAIN TO LIP 6-8 FOOT LONG	1
8	111-079	HOSE ASSEMBLY MAIN TO LIP 10 FOOT LONG	1
9	111-212	HOSE ASSEMBLY BOTTOM OF MAIN TO TOP	1
10	111-170	FITTING, ELBOW SWIVEL	1
11	111-071	FITTING, ELBOW	1
11A	111-206	VALVE, SOLENIOD (OPTIONAL) REPLACES ITEM #11 FOR E-STOP OR INDEPENDANT LIP	1
12	111-220	FUSE, VELOCITY	1
12A	111-366	FUSE, VELOCITY WITH E-STOP	1
13	111-208	FITTING, TEE	
14	111-210	FITTING, TEE	1
15	111-070	FITTING, ELBOW	2
16	111-066	FITTING, ELBOW SWIVEL	2
17	113-264	PIN, CLEVIS LIP	2
18	113-064	PIN, CLEVIS MAIN	2
19	113-073	PIN COTTER	4
20	112-071	WASHER, FLAT	4

¹ Provide length and diameter of hose when calling or faxing orders.

² Provide dock leveler serial number, voltage, and phase when calling or faxing orders.

Weather Seal, Rubber Style and Toe Guards

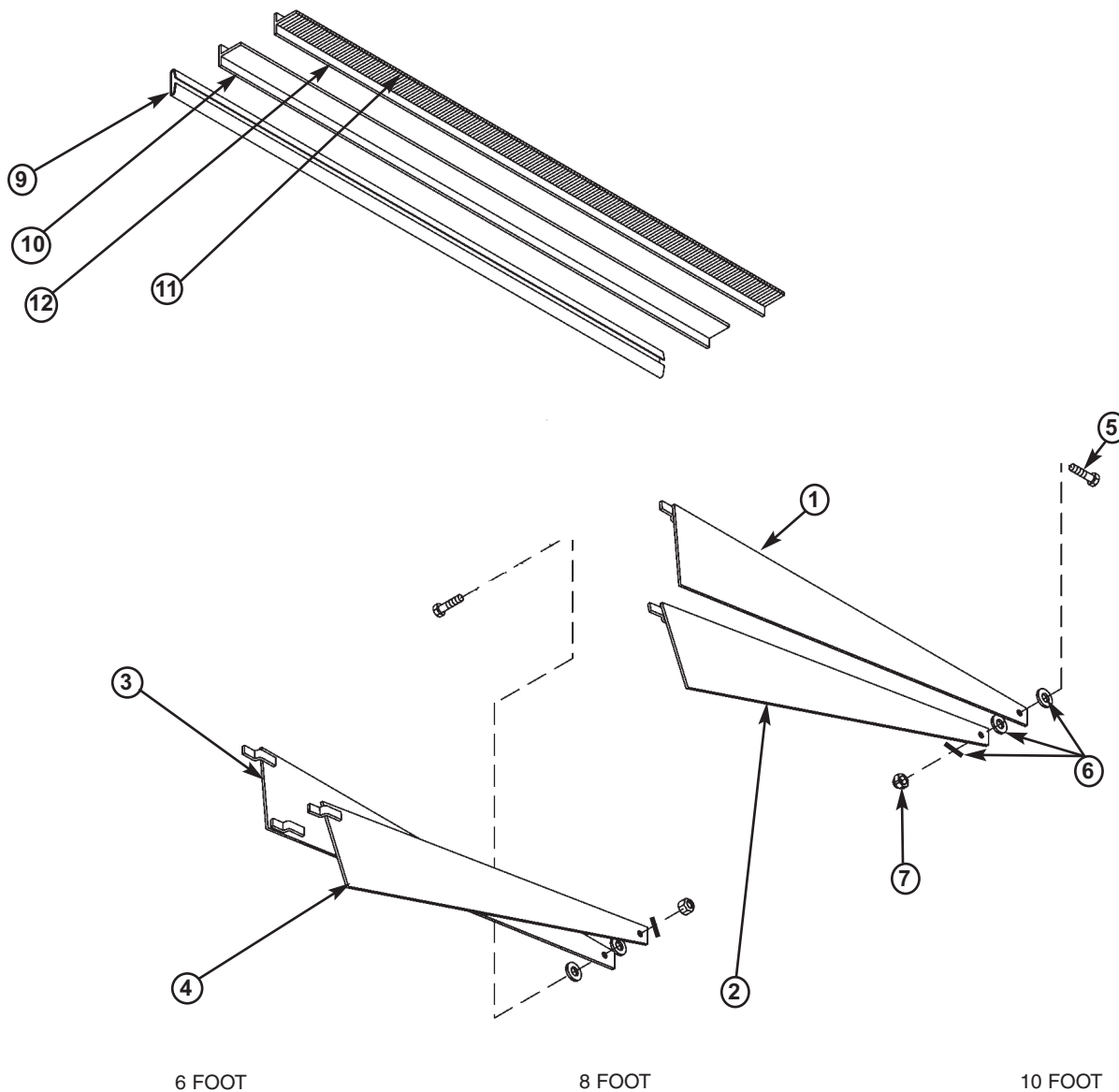

	6 FOOT	8 FOOT	10 FOOT
* 1	1 0014-0062 TOE GUARD LH MIDDLE	0014-0070 TOE GUARD LH MIDDLE	0014-0078 TOE GUARD LH MIDDLE
2	1 0014-0066 TOE GUARD LH LOWER	0014-0074 TOE GUARD LH LOWER	0014-0082 TOE GUARD LH LOWER
3	1 0014-0064 TOE GUARD RH MIDDLE	0014-0072 TOE GUARD RH MIDDLE	0014-0080 TOE GUARD RH MIDDLE
4	1 0014-0068 TOE GUARD RH LOWER	0014-0076 TOE GUARD RH LOWER	0014-0084 TOE GUARD RH LOWER
5	2 OTH-2043 SCREW CAP		SAME
6	6 OTH-2207 WASHER		SAME
7	2 OTH-2131 LOCK NUT		SAME
9	2 DOTH-2841 CHANNEL WEATHER SEAL	DOTH-2840 CHANNEL WEATHER SEAL	DOTH-2843 CHANNEL WEATHER SEAL
10	2 DOTH-2824 T-RUBBER WEATHER SEAL	DOTH-2824 T-RUBBER WEATHER SEAL	CONSULT FACTORY
11	2 DOTH-2822 BRUSH WEATHER SEAL	DOTH-2822 BRUSH WEATHER SEAL	CONSULT FACTORY
12	2 DOTH-2821 EXTRUSION ALUM.	DOTH-2820 EXTRUSION ALUM.	CONSULT FACTORY
* *	1 DKIT-9179 FRTG. COMPLETE R&L	DKIT-9180 FRTG. COMPLETE R&L	DKIT-9181 FRTG. COMPLETE R&L

PARTS Motor and Pump

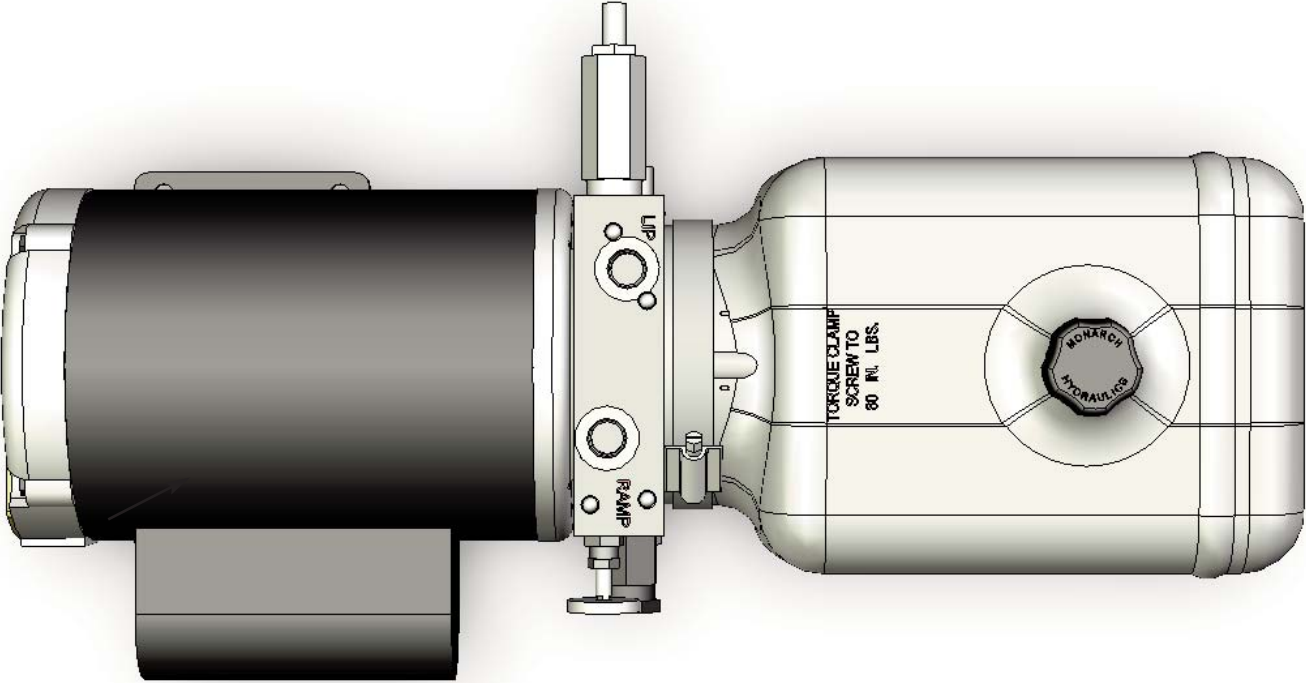

111-374	Reservoir, Pump with Motor Drive Plate Single Phase
111-375	Reservoir, Pump with Motor Drive Plate Three Phase

¹ Provide dock leveler serial number and type of installation when calling or faxing orders.

² Provide dock leveler serial number, voltage, and phase when calling or faxing orders.

NOTES

A large, empty rectangular box with a thin black border, occupying most of the page below the 'NOTES' header. It is intended for handwritten or typed notes.

MISCELLANEOUS

Customer Information

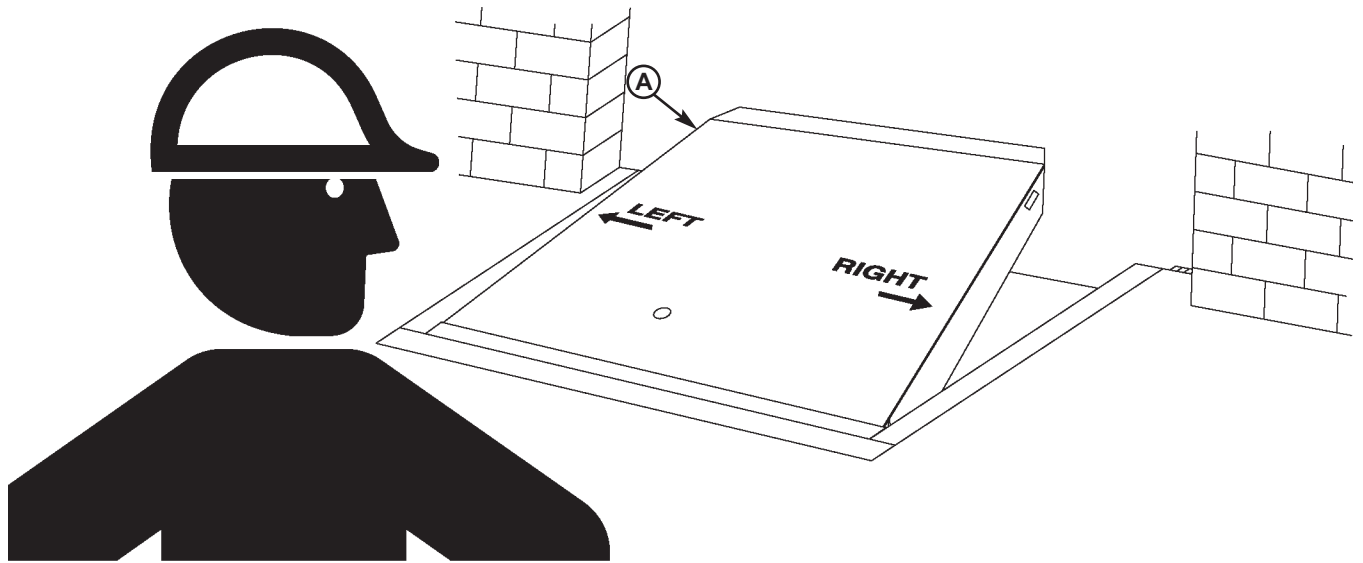

NOTE: Refer to illustration for left/right orientation of dock leveler.

The model/serial number decal (A) is located on the left platform joist near the front (lip) of dock leveler.

When you receive your HP/H dock leveler, write down the dock leveler model and serial number in the form provided. This will help ensure safe keeping of the numbers in the event the model/serial number decal (A) becomes lost or damaged.

Also, write down McGuire's job number, the company that installed the dock leveler, and the original owner's name. This will all help to identify the specific dock leveler if more information is required.

When ordering, use part numbers and description to help identify the item ordered. Do not use "item" numbers. These are only for locating the position of the parts. Always give dock leveler MODEL NUMBER and/or SERIAL NUMBER.

For service, call or contact:

Systems, Inc.
P.O. Box 309
Germantown, WI 53022

Phone: (800) 624-8473
Fax: (262) 255-9399

<u>Dock Leveler Information</u>	
Model	_____
Serial No.	_____
McGuire's, Job No.	_____
<u>Original Owner Information</u>	
Name	_____
Address	_____ _____
<u>Installer Information</u>	
Name	_____
Address	_____ _____
Date of Installation	_____

McGUIRE. WARRANTY

HP/H SERIES LEVELER

McGuire., guarantees the materials, components, and workmanship in your McGuire HP/H dock leveler to be of the highest quality and to be free of defects in material and workmanship for a full One (1) Year Base Warranty on the structural, hydraulic and electrical. Additional 4 years pro rated based on application, from date of shipment, specifically the deck section, lip section, frame, rear hinge, front hinge for the HP series. The H series also carries the 4 year warranty and is NOT pro rated, based on application.

Specifically this guarantee applies to:

- All hydraulic cylinders
- Hydraulic pressure lines
- Hydraulic pump and motor.

In the event of any defect covered by this guarantee, McGuire, will remedy said defect by repairing or replacing all defective parts, bearing all of the costs for parts, labor, and transportation.

All guarantee claims will be settled on a timely basis when defects are found to be from other than improper installation, operating contrary to instructions or beyond rated load capacities, abuse, careless or negligent use, or failure to maintain the unit as recommended by the owner's manual.

There are no guarantees, either expressed or implied, including any implied guarantees of merchantability or fitness for a particular purpose which shall extend beyond the guarantee periods indicated above. This guarantee is valid only if the unit(s) is unaltered from original condition as delivered from the factory and a survey is completed by a McGuire representative.