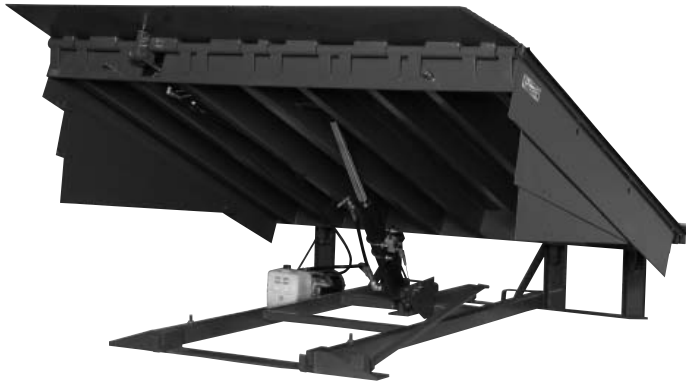

HYDRAULIC DOCK LEVELER

* HP7840 shown with optional auto return to dock and optional weather seal.

- ▶ Easy push button operation for smooth, consistent operation with a hydraulic system that provides for full float at all positions
- ▶ Positive lip extension and retraction with true regenerative hydraulic control
- ▶ Below dock end load capability
- ▶ Full width rear hinge mounted in compression with structural channel support
- ▶ Velocity fuse hydraulic fail safe stops platform within 1" to 3" in free fall situation
- ▶ Subframe design allows for easy quick pit clean out
- ▶ Integral maintenance strut is lockout/tagout compliant

GENERAL DESCRIPTION: All McGuire HP Series dock levelers incorporate the use of hydraulics to raise and lower both the platform and lip. A single push button activates a hydraulic pump for operating both lip and hoist cylinders. Systems, Inc. is an active member of Loading Dock Equipment Manufacturers (LODEM), a product section of the Material Handling Industry. Unit conforms to OSHA, U.S. Department of Commerce Standard CS-202-56 and is manufactured in compliance with the American National Standard of Safety Performance and Testing of Dock Leveling Devices (ANSI) MH 30.1. Unit manufactured by McGuire.

OPERATION: The HP Series Lever is controlled remotely from a wall mounted control panel. An array of optional control panel features are available. Service range is from 12" above to 12" below dock level. Lip keepers welded to frame members provide night time security and cross-traffic support. Full operating range toe guards are provided as standard. Maintenance strut with lockout/tagout capability is provided as standard. Factory finish includes rust inhibitive coat industrial grade finish. Special coating and colors are optional.

CONSTRUCTION: The platform is constructed of 1/4" thick 4-way high tensile 50,000 minimum yield A572 safety tread plate. Platform is reinforced and supported by full length 6" height "C" channels welded to deck and front and rear header for firm structural support. Front and rear header plate is 1/2" thick x 7" high hot rolled steel. McGuire HP series lips are 4-way safety tread plate, the 25,000 lb CIR is 1/2" thick, or the 30,000, 35,000 and 40,000 lb CIR are 5/8" thick. The standard lip length is 16" on all capacities. Hinge tubes are 1 3/4" OD x 5/16" wall, 1 7/8" OD x 3/8" wall or 2 1/8" OD x 1/2" wall depending on CIR. All lip hinge pins are 1" diameter M1044 steel. Steel header gussets are standard on all models 35,000 lb CIR and above. All units have grease fittings as standard. All platforms are designed to compensate for up to 4" of canted trailer bed.

HYDRAULICS: Platform is raised by a main hydraulic cylinder; all hydraulic hoses are routed under the leveler platform, away from debris. Hoist cylinder is a hard chrome-plated double acting design with a 3" ID bore. Main cylinder is equipped with a velocity safety stop to limit free fall of a loaded platform to 3" (+/- 1"). Lip operation is controlled by a hard chrome plated cylinder having a 2" ID bore and is fully yieldable. Motor pump is mounted up for easy access and to clear debris in pit. Reservoir is translucent for monitoring of fluid level.

SAFETY EQUIPMENT: Standard non-adjustable hydraulic velocity fuse limits platform free fall to 3" (+/- 1") with heavy load on platform. Full range telescoping toe guards close off leveler sides even in highest upward position. Lip keepers are cross traffic support and serve as automatic night lock security against break in attempts. Built in maintenance inspection strut that is lockout/tagout compliant is included. HP series can be equipped with STOP-TITE™ or HOLD-TITE™ series vehicle restraint devices or Light Communication System signs and lights.

COLORS: Levelers painted slate blue. Other colors available. Consult factory.

DOCK BUMPERS: Two molded 4" thick x 12" high x 13" wide bumpers as standard. Optional sizes and types are available.

VEHICLE RESTRAINT SYSTEMS: McGuire HP Series hydraulic levelers can be equipped with STOP-TITE™ or a HOLD-TITE™ series vehicle restraint or a Light Communication System to help prevent unexpected trailer departure from the loading dock and minimize trailer creep during the loading/unloading process and to enhance communication at the dock area.

ELECTRICAL: Hydraulic pump motor either 1 HP TENV at 120v or 208v, single phase or at 208v, 230v, 460v, or 575v three phase. Electrical control panel is NEMA 12 enclosure. All electrical components, connections and wiring are UL listed or recognized. Please Note: Unless specifically noted on quotation, all electrical requirements are the responsibility of others.

WARRANTY: All McGuire HP Series models feature a full one (1) year base warranty on all structural, hydraulic and electrical parts, including freight and labor charges in accordance with McGuire's standard warranty policy. Structural and hydraulic components carry an additional full four (4) year pro-rated warranty. McGuire warrants all components to be free of defects in materials and workmanship, under normal use, during the warranty period. This base warranty period begins upon the completion of installation or the sixtieth (60th) day after shipment, whichever is earlier. Additional warranty extensions may be available upon approved submittal of application information.



A Division of Systems, Inc.

HP SERIES

HYDRAULIC DOCK LEVELER

Optional Equipment for HP Series Hydraulic Dock Levelers

Check Options Desired

- 18" Lip
- 20" Lip
- Auto return to dock (all positions)
- Rubber weather seal
- Brush weather seal
- 3 wheel fork truck protection
- Non-metallic single push button control (non-interlock)
- Lip extend only button
- Mushroom style E-stop button
- Integrated control panel
- Autogard barrier lip (5" projection)
- Pit steel (6 piece curb angle set)
- Pit steel (4 angle/2 bumper plates)
- Pit kit (3 sided)
- Pan unit (4 sided)
- Clean Pit® (frame removed)
- Foam insulation
- Special color _____
- Yellow and black toe guard safety tape
- Laminated bumpers
 - B410-14 (horizontal)
 - VB420-11 (vertical)
 - VB424-11 (vertical)
 - 6" thick dock bumpers
 - Steel faced
- HOLD-TITE™ restraint
- STOP-TITE™ restraint (manual)
- STOP-TITE™ restraint (automatic)
- Light Communication System
- Wheel chocks model # _____
- Dock light (no bulb) model # _____

Dimensions and Capacities

Select a Model and a Capacity

HP MODEL - NOMINAL SIZE

CAPACITY-COMPARATIVE INDUSTRY RATING (CIR)

- HP-66 6' x 6'
- HP-68 6' x 8'
- HP-610 6' x 10'
- HP-656 6'6" x 6'
- HP-658 6'6" x 8'
- HP-6510 6'6" x 10'
- HP-76 7' x 6'
- HP-78 7' x 8'
- HP-710 7' x 10'

- 25,000 LBS. CIR
- 30,000 LBS. CIR
- 35,000 LBS. CIR
- 40,000 LBS. CIR

Customer: _____

Job: _____

Location: _____

Number of Units: _____

Model: _____

Voltage/Phase: _____

Represented By: _____

Sales Rep: _____

Certified for Construction:

By: _____

Title: _____

Date: _____

Company: _____

City: _____

State: _____

Consistent with our policy of continuing product improvement, we reserve the right to change product specifications without notice or obligation.

McGuire • Division of Systems, Inc. • W194 N11481 McCormick Dr. • P.O. Box 309 • Germantown, WI 53022
Phone: 800.624.8473 • Fax: 262.255.9399 • www.wbmcguire.com

DOCK LEVELER